

THE INFORMATION CONTAINED IN THIS DRAWING IS THE SOLE PROPERTY OF RYADON INC. ANY REPRODUCTION IN PART OR AS A WHOLE WITHOUT THE WRITTEN PERMISSION OF RYADON INC. IS PROHIBITED.

NOTES:

- 1.) DO NOT SCALE DRAWING.
- 2.) REMOVE ALL BURRS, NO SHARP EDGES.
- 3.) MUST NOT HAVE SCRATCHES, DINGS, OR DENTS.
- 4.) PART TO BE FREE FROM SURFACE IMPERFECTIONS OTHER THAN SURFACE FINISH REQUIREMENTS.
- 5.) CRITICAL DIMENSIONS ARE INDICATED BY:
- 6.) ALL ITEMS ARE TO BE INSPECTED TO 2.5 AQL SAMPLING PLAN UNLESS OTHER WISE STATED.
- 7.) ENSURE PACKAGING WILL PROVIDE ADEQUATE PROTECTION DURING TRANSPORT.

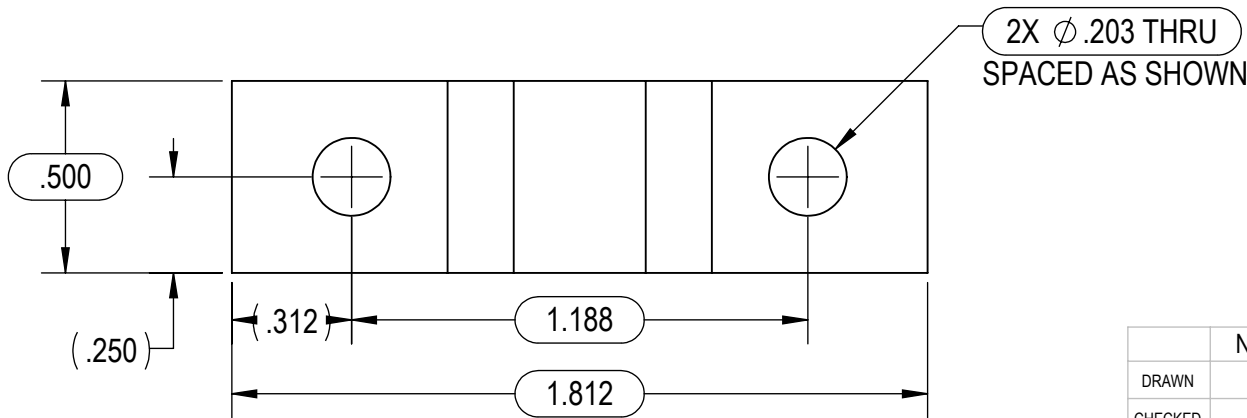
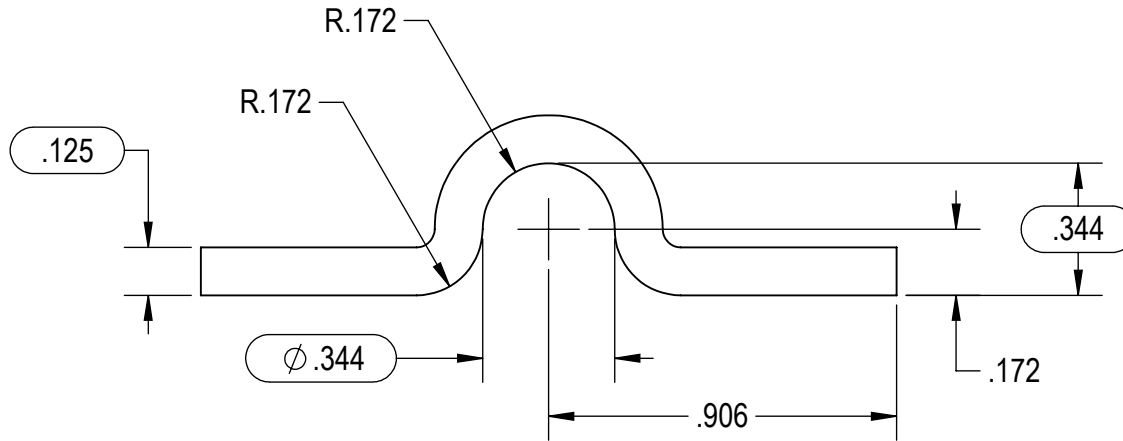
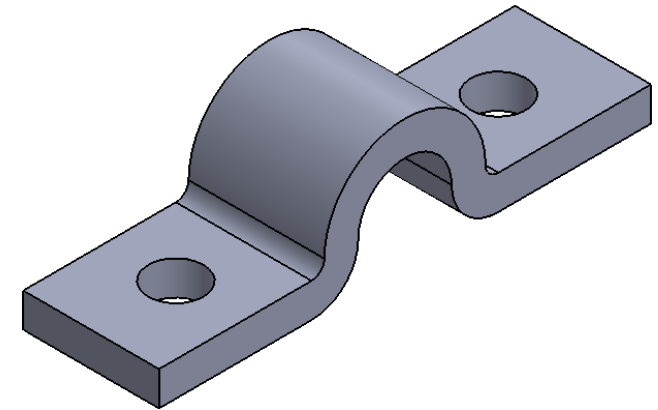

	NAME	DATE
DRAWN	KAS	04/09/14
CHECKED	MB	07/14/14
ENG.	KAS	07/14/14
Q.A.	AH	07/14/14

RYADON INC.
QUALITY - INTEGRITY - VALUE

DESCRIPTION:

ROD GUIDE

MATERIAL: **STEEL** FINISH: **ZINC PLATE**

SIZE PART NO.

A R-G01

REV
A

THIRD ANGLE PROJECTION



UNLESS OTHERWISE SPECIFIED:
DIMENSIONS ARE IN INCHES
TOLERANCES:
FRACTIONAL $\pm 1/32"$
ANGULAR: MACH $\pm 1^\circ$ BEND $\pm 1^\circ$
TWO PLACE DECIMAL $\pm .03$
THREE PLACE DECIMAL $\pm .015$
INTERPRET GEOMETRIC
TOLERANCING PER:

COMMENTS:

REVISIONS			
REV.	DESCRIPTION	DATE	APPROVED
A	INITIAL RELEASE	4/9/2014	KAS