

THE INFORMATION CONTAINED IN THIS DRAWING IS THE SOLE PROPERTY OF RYADON INC. ANY REPRODUCTION IN PART OR AS A WHOLE WITHOUT THE WRITTEN PERMISSION OF RYADON INC. IS PROHIBITED.

**NOTES:**

- 1.) DO NOT SCALE DRAWING.
- 2.) REMOVE ALL BURRS, NO SHARP EDGES.
- 3.) MUST NOT HAVE SCRATCHES, DINGS, OR DENTS.
- 4.) PART TO BE FREE FROM SURFACE IMPERFECTIONS OTHER THAN SURFACE FINISH REQUIREMENTS.
- 5.) CRITICAL DIMENSIONS ARE INDICATED BY: 
- 6.) ALL ITEMS ARE TO BE INSPECTED TO 2.5 AQL SAMPLING PLAN UNLESS OTHER WISE STATED.

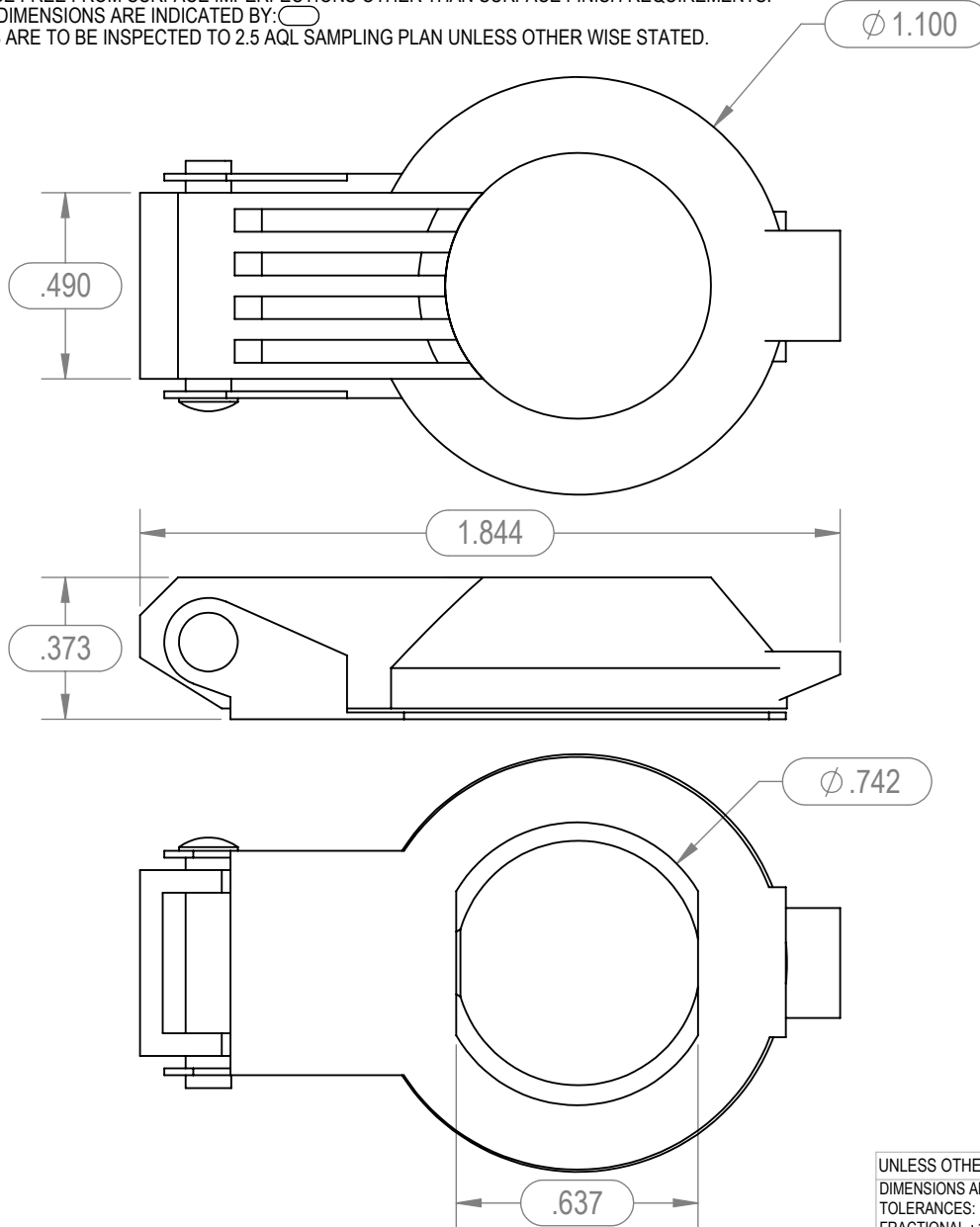
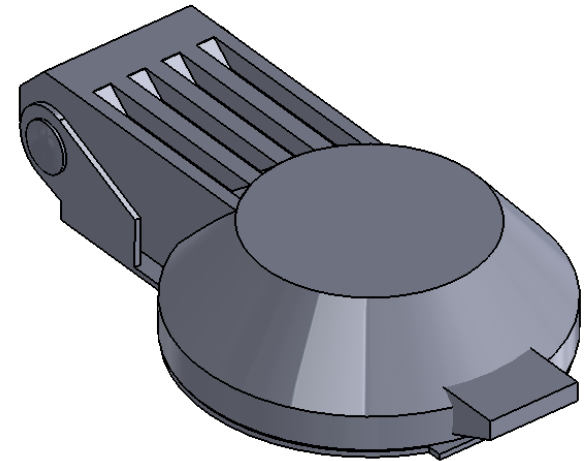

	NAME	DATE
DRAWN	KAS	01/06/14
CHECKED		
ENG.		
Q.A.		

**RYADON INC.**  
QUALITY - INTEGRITY - VALUE

DESCRIPTION:  
**DUSTCOVER, EXTERNAL**

MATERIAL: N/A FINISH: N/A  
 SIZE PART NO. REV  
**A L-6881 A**

UNLESS OTHERWISE SPECIFIED:  
 DIMENSIONS ARE IN INCHES  
 TOLERANCES:  
 FRACTIONAL ± 1/32"  
 ANGULAR: MACH ± 1° BEND ± 1°  
 TWO PLACE DECIMAL ± .03  
 THREE PLACE DECIMAL ± .015  
 INTERPRET GEOMETRIC TOLERANCING PER:

COMMENTS:  
 THIRD ANGLE PROJECTION

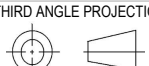

SCALE: 2:1 DO NOT SCALE DRAWING SHEET 1 OF 1

REVISIONS			
REV.	DESCRIPTION	DATE	APPROVED
A	INITIAL RELEASE	1/6/2014	KAS