

$\phi .320$ THRU
 $\square \phi .500$
 $(\sphericalangle 90^\circ \downarrow .130)$
 4X SPACED AS SHOWN

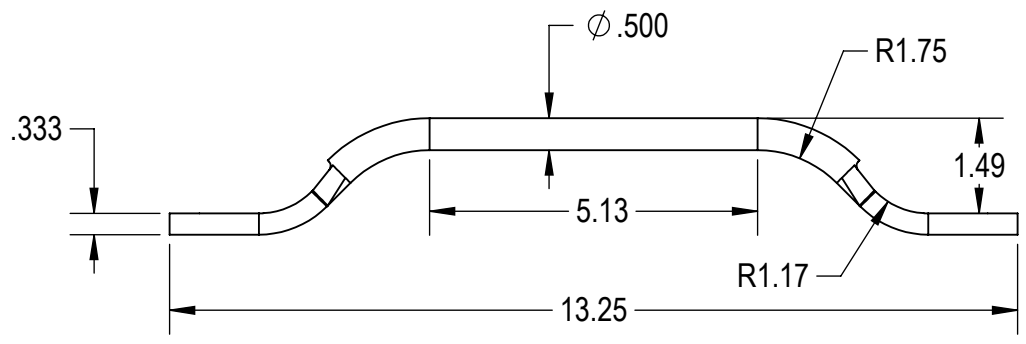

- NOTES:
- 1.) DO NOT SCALE DRAWING.
 - 2.) REMOVE ALL BURRS, NO SHARP EDGES.
 - 3.) MUST NOT HAVE SCRATCHES, DINGS, OR DENTS.
 - 4.) PART TO BE FREE FROM SURFACE IMPERFECTIONS OTHER THAN SURFACE FINISH REQUIREMENTS.
 - 5.) CRITICAL DIMENSIONS ARE INDICATED BY: \square
 - 6.) ALL ITEMS ARE TO BE INSPECTED TO 2.5 AQL SAMPLING PLAN UNLESS OTHERWISE STATED.
 - 7.) ENSURE PACKAGING WILL PROVIDE ADEQUATE PROTECTION DURING TRANSPORT.

DEPT.	NAME	DATE
DRAWN	KAS	05/2/14
SALES	BW	6/10/14
ENG.	KAS	6/10/14
Q.A.	AH	6/10/14

UNLESS OTHERWISE SPECIFIED:
 DIMENSIONS ARE IN INCHES
 TOLERANCES:
 FRACTIONAL $\pm 1/32"$
 ANGULAR: MACH $\pm 1^\circ$ BEND $\pm 1^\circ$
 TWO PLACE DECIMAL $\pm .03$
 THREE PLACE DECIMAL $\pm .015$
 INTERPRET GEOMETRIC TOLERANCING PER:

DESCRIPTION:
 HANDLE
 MATERIAL:
 304 STAINLESS STEEL
 FINISH:
 POLISHED
 COMMENTS:



REVISIONS		
REV.	DESCRIPTION	DATE
A	INITIAL RELEASE	5/2/14

SIZE PART NO.
A I-GH10.0-SS

THE INFORMATION CONTAINED IN THIS DRAWING IS THE SOLE PROPERTY OF RYADON INC. ANY REPRODUCTION IN PART OR AS A WHOLE WITHOUT THE WRITTEN PERMISSION OF RYADON INC. IS PROHIBITED.

SCALE: 1:3 DO NOT SCALE DRAWING SHEET 1 OF 1