

RECOMMENDED

INNER SLIDE MEMBER:

#10 MACHINE OR WOOD PAN HEAD SCREW FOR ALL THRU HOLES AND SLOTTED THRU HOLES

OUTER SLIDE MEMBER:

#10 MACHINE OR WOOD FLAT HEAD SCREW FOR ALL THRU HOLES AND SLOTTED THRU HOLES

SIDE SPACE:

.753" - .780"

NOTES:

- DO NOT SCALE DRAWING.
- REMOVE ALL BURRS, NO SHARP EDGES.
- MUST NOT HAVE SCRATCHES, DINGS, OR DENTS.
- PART TO BE FREE FROM SURFACE IMPERFECTIONS OTHER THAN SURFACE FINISH REQUIREMENTS.
- CRITICAL DIMENSIONS ARE INDICATED BY:
- ALL ITEMS ARE TO BE INSPECTED TO 2.5 AQL SAMPLING PLAN UNLESS OTHERWISE STATED.
- ENSURE PACKAGING WILL PROVIDE ADEQUATE PROTECTION DURING TRANSPORT.
- GEOMETRIC FEATURES NOT DIMENSIONED ARE CONTROLLED BY 3D MODEL.

THE INFORMATION CONTAINED IN THIS DRAWING IS THE SOLE PROPERTY OF RYADON INC. ANY REPRODUCTION IN PART OR AS A WHOLE WITHOUT THE WRITTEN PERMISSION OF RYADON INC. IS PROHIBITED.

REVISIONS			DEPT.	NAME	DATE
REV.	DESCRIPTION	DATE	SALES	MB	6/27/18
1	INITIAL RELEASE	6/27/18	ENG.	NS	6/27/18
			Q.A.	PN	6/27/18
TOLERANCES UNLESS OTHERWISE SPECIFIED: .X = ± .05 .XX = ± .03 .XXX = ± .015 .XXXX = ± .008 X/X = ± 1/32" ANGLE = ± 1° SURFACE = ± $\sqrt{.125}$			DESCRIPTION: 2250 SERIES 8" SLIDE		
MATERIAL: STEEL			RYADON INC.		
FINISH: ZINC PLATED			SIZE A	PART No. I-DS-2250-8	
SCALE: NTS			SHEET 1 OF 1		REV 1
			DRAWN BY/DATE NAS 06/27/18		

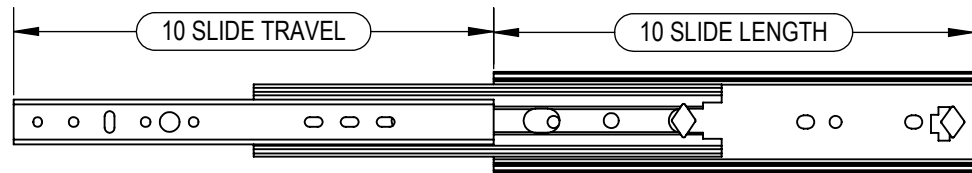
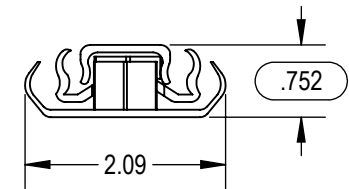
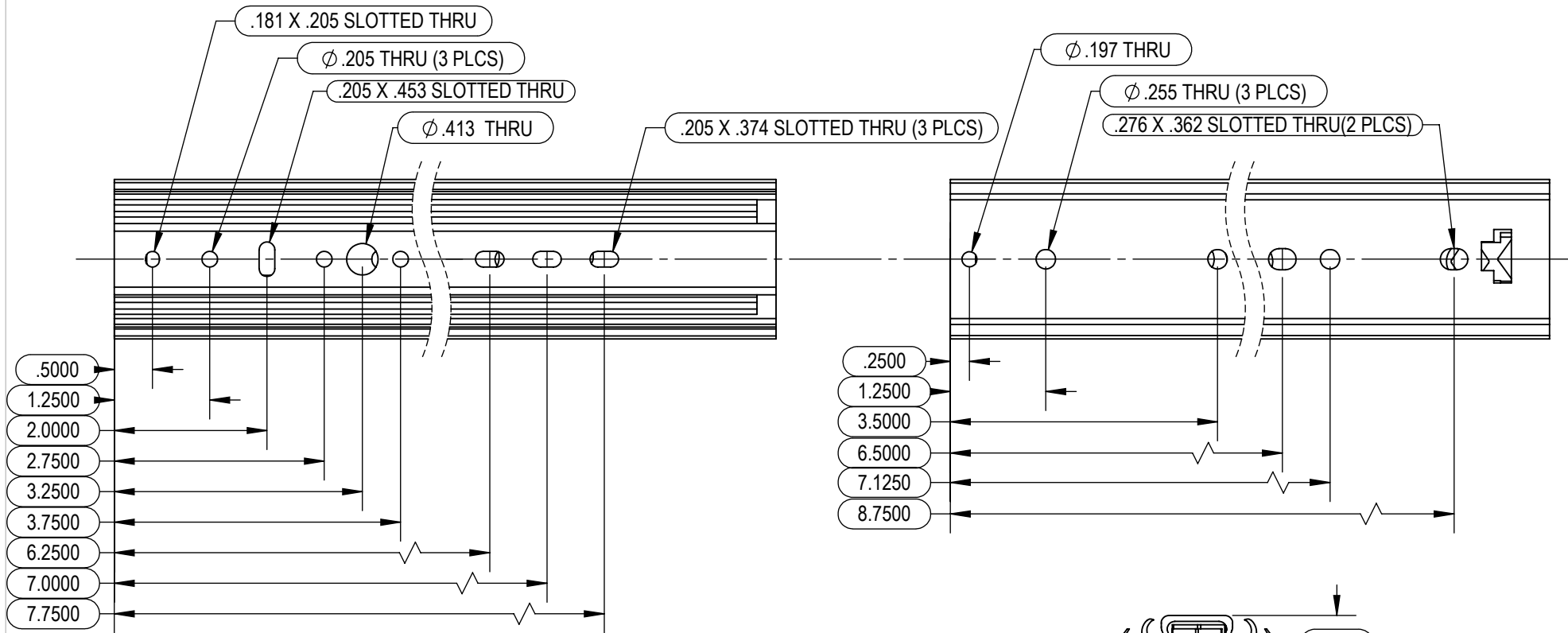

RECOMMENDED
 INNER SLIDE MEMBER:
 #10 MACHINE OR WOOD PAN HEAD SCREW FOR ALL THRU HOLES AND SLOTTED THRU HOLES

OUTER SLIDE MEMBER:
 1/4 HEX BOLT, #14 PAN HEAD WOOD SCREW FOR ALL THRU HOLES AND SLOTTED THRU HOLES

SIDE SPACE:
 .753" - .780"

- NOTES:**
- DO NOT SCALE DRAWING.
 - REMOVE ALL BURRS, NO SHARP EDGES.
 - MUST NOT HAVE SCRATCHES, DINGS, OR DENTS.
 - PART TO BE FREE FROM SURFACE IMPERFECTIONS OTHER THAN SURFACE FINISH REQUIREMENTS.
 - CRITICAL DIMENSIONS ARE INDICATED BY:
 - ALL ITEMS ARE TO BE INSPECTED TO 2.5 AQL SAMPLING PLAN UNLESS OTHERWISE STATED.
 - ENSURE PACKAGING WILL PROVIDE ADEQUATE PROTECTION DURING TRANSPORT.
 - GEOMETRIC FEATURES NOT DIMENSIONED ARE CONTROLLED BY 3D MODEL.

THE INFORMATION CONTAINED IN THIS DRAWING IS THE SOLE PROPERTY OF RYADON INC. ANY REPRODUCTION IN PART OR AS A WHOLE WITHOUT THE WRITTEN PERMISSION OF RYADON INC. IS PROHIBITED.

REVISIONS			DEPT.	NAME	DATE
REV.	DESCRIPTION	DATE	SALES	MB	6/28/18
1	INITIAL RELEASE	06/28/18	ENG.	NS	6/28/18
			Q.A.	PN	6/28/18

TOLERANCES UNLESS OTHERWISE SPECIFIED: .X = ± .05 .XX = ± .03 .XXX = ± .015 .XXXX = ± .008 X/X = ± 1/32" ANGLE = ± 1° SURFACE = ±		DESCRIPTION: 2250 SERIES 10" SLIDE	RYADON INC. 	MATERIAL: STEEL	SIZE A	PART No. I-DS-2250-10-QD	REV 1
		FINISH: ZINC PLATED		SCALE: NTS	SHEET 1 OF 1	DRAWN BY/DATE NAS 06/28/18	

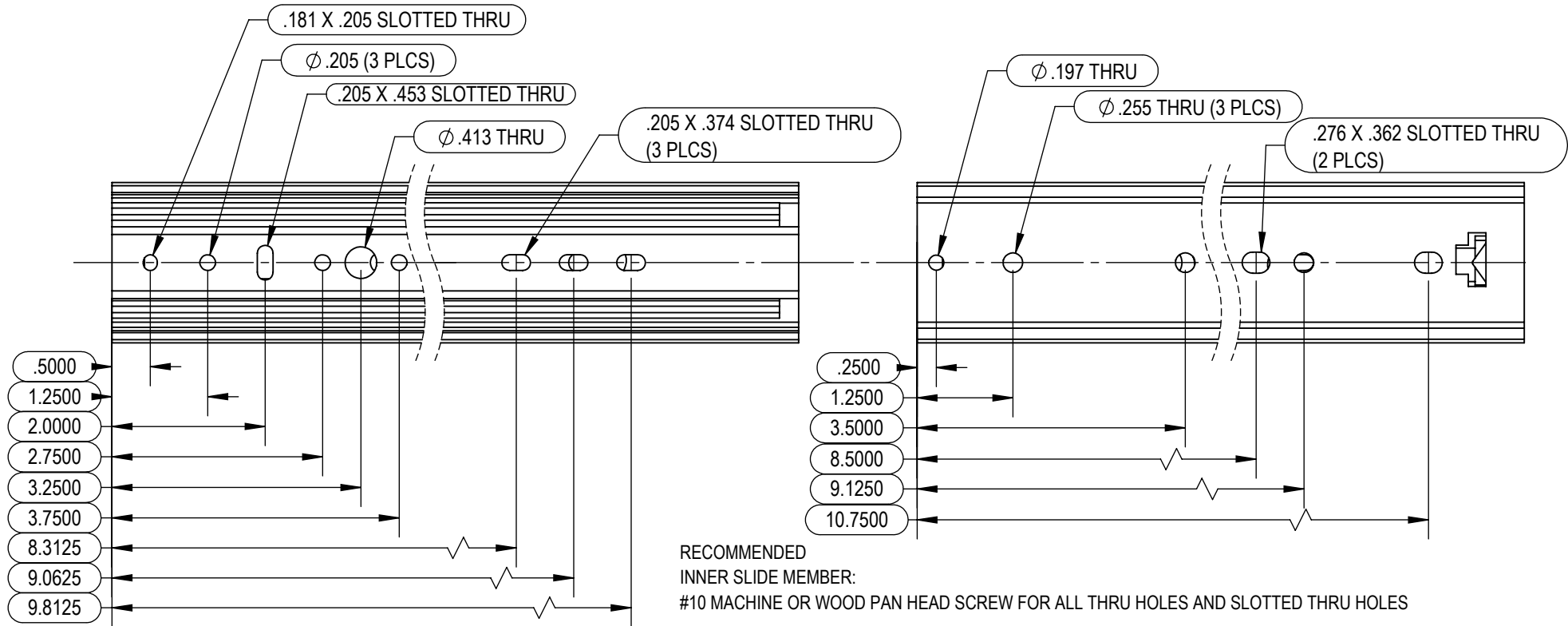

RECOMMENDED
INNER SLIDE MEMBER:
#10 MACHINE OR WOOD PAN HEAD SCREW FOR ALL THRU HOLES AND SLOTTED THRU HOLES

OUTER SLIDE MEMBER:
1/4 HEX BOLT, #14 PAN HEAD WOOD SCREW FOR ALL THRU HOLES AND SLOTTED THRU HOLES

SIDE SPACE:
.753" - .780"

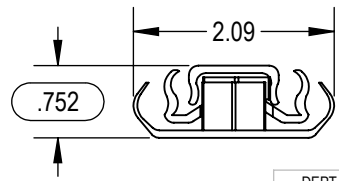
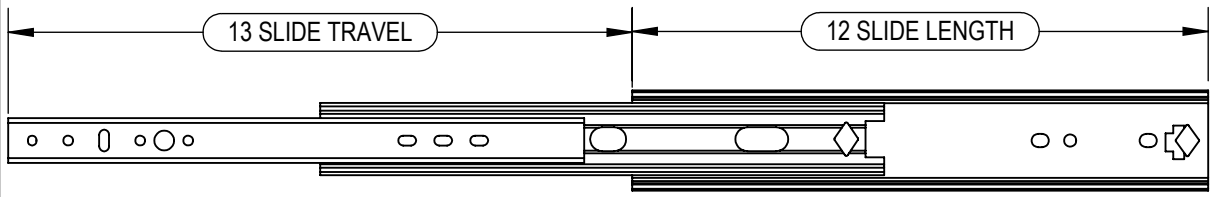

- NOTES:**
- DO NOT SCALE DRAWING.
 - REMOVE ALL BURRS, NO SHARP EDGES.
 - MUST NOT HAVE SCRATCHES, DINGS, OR DENTS.
 - PART TO BE FREE FROM SURFACE IMPERFECTIONS OTHER THAN SURFACE FINISH REQUIREMENTS.
 - CRITICAL DIMENSIONS ARE INDICATED BY:
 - ALL ITEMS ARE TO BE INSPECTED TO 2.5 AQL SAMPLING PLAN UNLESS OTHERWISE STATED.
 - ENSURE PACKAGING WILL PROVIDE ADEQUATE PROTECTION DURING TRANSPORT.
 - GEOMETRIC FEATURES NOT DIMENSIONED ARE CONTROLLED BY 3D MODEL.

THE INFORMATION CONTAINED IN THIS DRAWING IS THE SOLE PROPERTY OF RYADON INC. ANY REPRODUCTION IN PART OR AS A WHOLE WITHOUT THE WRITTEN PERMISSION OF RYADON INC. IS PROHIBITED.

REVISIONS			DEPT.	NAME	DATE
REV.	DESCRIPTION	DATE	SALES	MB	06/28/18
1	INITIAL RELEASE	06/28/18	ENG.	NS	06/28/18
			Q.A.	PN	06/28/18

TOLERANCES UNLESS OTHERWISE SPECIFIED: .X = ± .05 .XX = ± .03 .XXX = ± .015 .XXXX = ± .008 X/X = ± 1/32" ANGLE = ± 1° SURFACE = ±		DESCRIPTION: 2250 SERIES 12" SLIDE	RYADON INC.	
MATERIAL:	STEEL	SIZE A	PART No.	I-DS-2250-12-QD
FINISH:	ZINC PLATED	SCALE: NTS	SHEET 1 OF 1	DRAWN BY/DATE NAS 06/28/18

REV 1

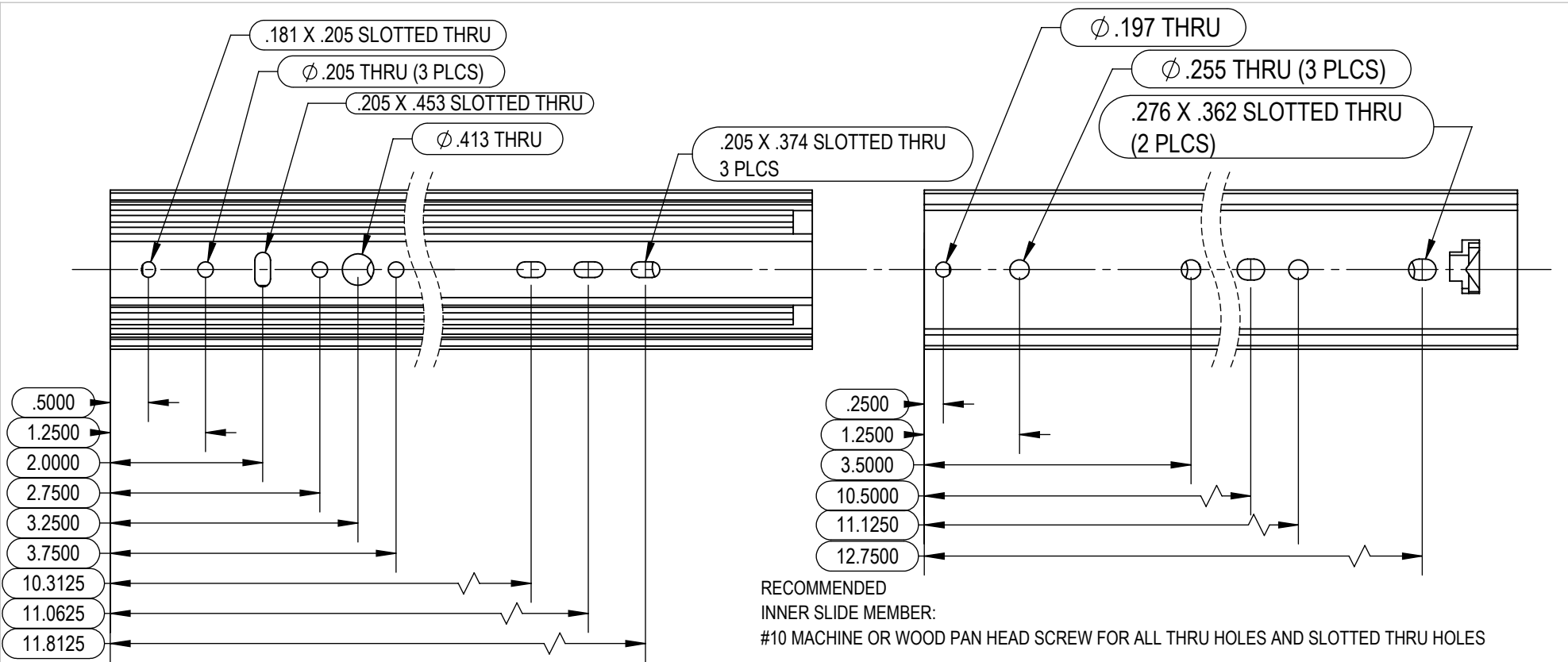

RECOMMENDED
INNER SLIDE MEMBER:
#10 MACHINE OR WOOD PAN HEAD SCREW FOR ALL THRU HOLES AND SLOTTED THRU HOLES

OUTER SLIDE MEMBER:
1/4 HEX BOLT, #14 PAN HEAD WOOD SCREW FOR ALL THRU HOLES AND SLOTTED THRU HOLES

SIDE SPACE:
.753" - .780"

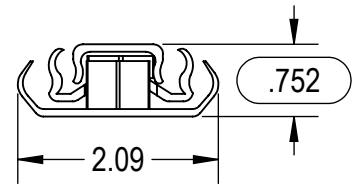
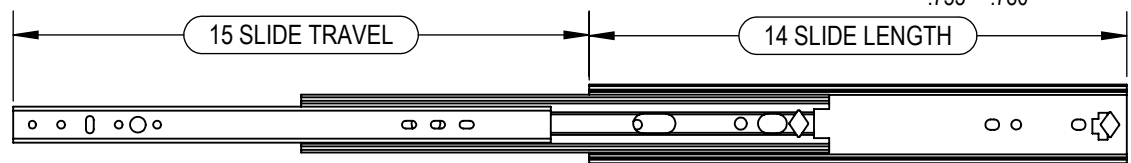

- NOTES:**
- 1.) DO NOT SCALE DRAWING.
 - 2.) REMOVE ALL BURRS, NO SHARP EDGES.
 - 3.) MUST NOT HAVE SCRATCHES, DINGS, OR DENTS.
 - 4.) PART TO BE FREE FROM SURFACE IMPERFECTIONS OTHER THAN SURFACE FINISH REQUIREMENTS.
 - 5.) CRITICAL DIMENSIONS ARE INDICATED BY:
 - 6.) ALL ITEMS ARE TO BE INSPECTED TO 2.5 AQL SAMPLING PLAN UNLESS OTHER WISE STATED.
 - 7.) ENSURE PACKAGING WILL PROVIDE ADEQUATE PROTECTION DURING TRANSPORT.
 - 8.) GEOMETRIC FEATURES NOT DIMENSIONED ARE CONTROLLED BY 3D MODEL.

REVISIONS			DEPT.	NAME	DATE
REV.	DESCRIPTION	DATE	SALES	MB	06/28/18
1	INITIAL RELEASE	06/28/18	ENG.	NS	06/28/18
			Q.A.	PN	06/28/18

<p>TOLERANCES UNLESS OTHERWISE SPECIFIED:</p> <p>.X = ± .05 .XX = ± .03 .XXX = ± .015 .XXX = ± .008 X/X = ± 1/32" ANGLE = ± 1° SURFACE = ± </p>		<p>DESCRIPTION: 2250 SERIES 14" SLIDE</p>	<p>RYADON INC.</p>		
<p>MATERIAL: STEEL</p>	<p>FINISH: ZINC PLATED</p>	<p>SIZE A</p>	<p>PART No. I-DS-2250-14-QD</p>	<p>REV 1</p>	

SCALE: NTS	SHEET 1 OF 1	DRAWN BY/DATE NAS 06/28/18
------------	--------------	-------------------------------

THE INFORMATION CONTAINED IN THIS DRAWING IS THE SOLE PROPERTY OF RYADON INC. ANY REPRODUCTION IN PART OR AS A WHOLE WITHOUT THE WRITTEN PERMISSION OF RYADON INC. IS PROHIBITED.

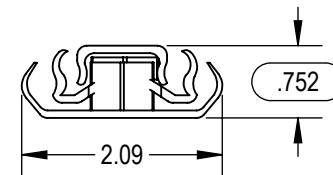
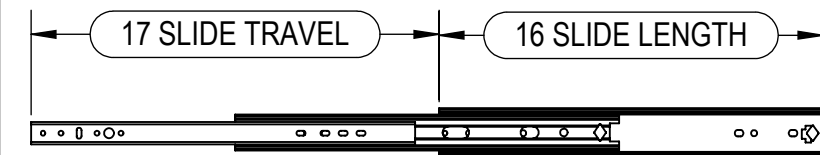
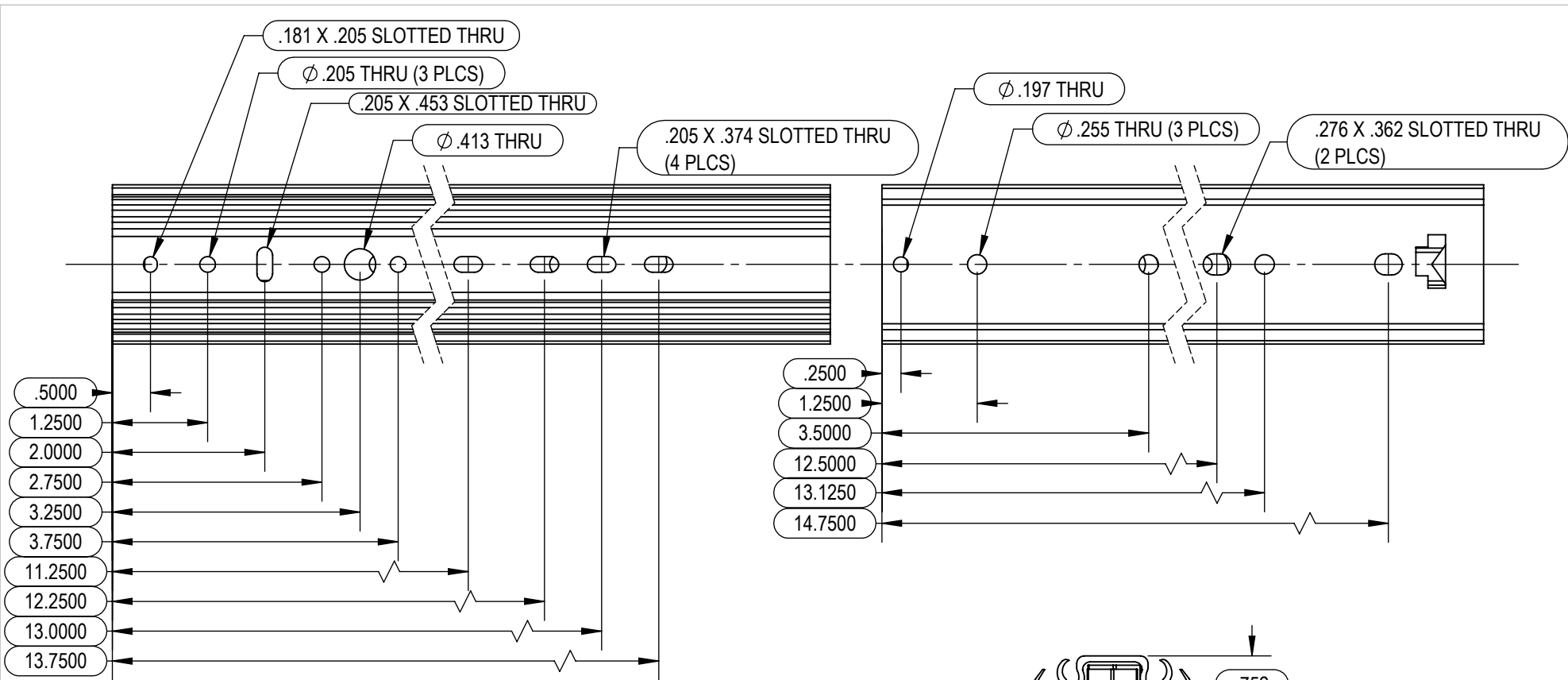

RECOMMENDED
INNER SLIDE MEMBER:

#10 MACHINE OR WOOD PAN HEAD SCREW FOR ALL THRU HOLES AND SLOTTED THRU HOLES

OUTER SLIDE MEMBER:

1/4 HEX BOLT, #14 PANHEAD WOOD SCREW FOR ALL THRU HOLES AND SLOTTED THRU HOLES

SIDE SPACE:

.753" - .780"

NOTES:

- 1.) DO NOT SCALE DRAWING.
- 2.) REMOVE ALL BURRS, NO SHARP EDGES.
- 3.) MUST NOT HAVE SCRATCHES, DINGS, OR DENTS.
- 4.) PART TO BE FREE FROM SURFACE IMPERFECTIONS OTHER THAN SURFACE FINISH REQUIREMENTS.
- 5.) CRITICAL DIMENSIONS ARE INDICATED BY:
- 6.) ALL ITEMS ARE TO BE INSPECTED TO 2.5 AQL SAMPLING PLAN UNLESS OTHERWISE STATED.
- 7.) ENSURE PACKAGING WILL PROVIDE ADEQUATE PROTECTION DURING TRANSPORT.
- 8.) GEOMETRIC FEATURES NOT DIMENSIONED ARE CONTROLLED BY 3D MODEL.

THE INFORMATION CONTAINED IN THIS DRAWING IS THE SOLE PROPERTY OF RYADON INC. ANY REPRODUCTION IN PART OR AS A WHOLE WITHOUT THE WRITTEN PERMISSION OF RYADON INC. IS PROHIBITED.

REVISIONS			DEPT.	NAME	DATE
REV.	DESCRIPTION	DATE	SALES	MB	06/28/18
1	INITIAL RELEASE	06/28/18	ENG.	NS	06/28/18
			Q.A.	PN	06/28/18

TOLERANCES UNLESS OTHERWISE SPECIFIED: .X = ± .05 .XX = ± .03 .XXX = ± .015 .XXXX = ± .008 X/X = ± 1/32" ANGLE = ± 1° SURFACE = ±		DESCRIPTION: 2250 SERIES 16" SLIDE	RYADON INC. 	
MATERIAL: STEEL	FINISH: ZINC PLATED	SIZE A		PART No. I-DS-2250-16-QD
		SCALE: NTS	SHEET 1 OF 1	DRAWN BY/DATE NAS 06/28/18

REV 1

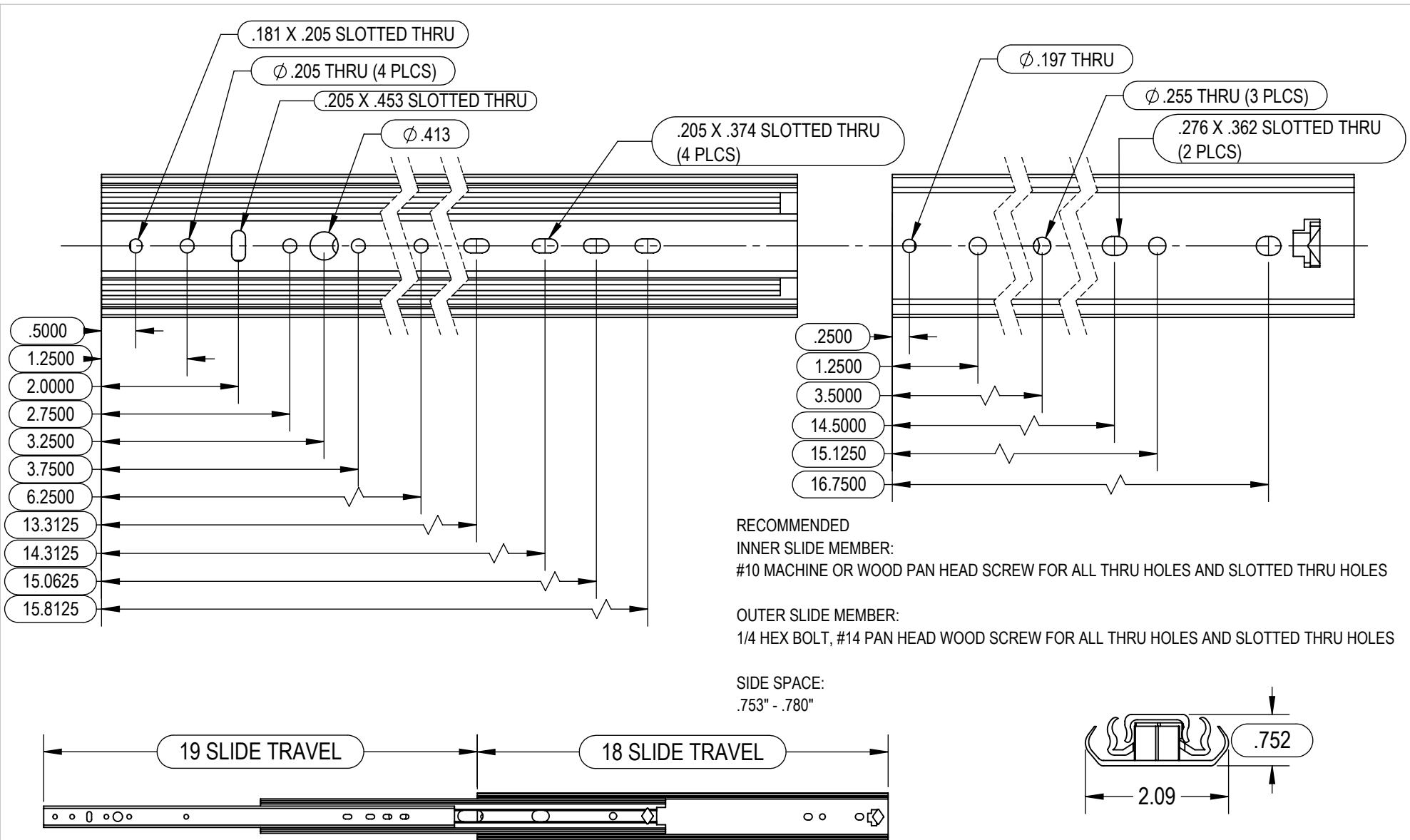

RECOMMENDED
INNER SLIDE MEMBER:
#10 MACHINE OR WOOD PAN HEAD SCREW FOR ALL THRU HOLES AND SLOTTED THRU HOLES

OUTER SLIDE MEMBER:
1/4 HEX BOLT, #14 PAN HEAD WOOD SCREW FOR ALL THRU HOLES AND SLOTTED THRU HOLES

SIDE SPACE:
.753" - .780"

NOTES:

- 1.) DO NOT SCALE DRAWING.
- 2.) REMOVE ALL BURRS, NO SHARP EDGES.
- 3.) MUST NOT HAVE SCRATCHES, DINGS, OR DENTS.
- 4.) PART TO BE FREE FROM SURFACE IMPERFECTIONS OTHER THAN SURFACE FINISH REQUIREMENTS.
- 5.) CRITICAL DIMENSIONS ARE INDICATED BY:
- 6.) ALL ITEMS ARE TO BE INSPECTED TO 2.5 AQL SAMPLING PLAN UNLESS OTHERWISE STATED.
- 7.) ENSURE PACKAGING WILL PROVIDE ADEQUATE PROTECTION DURING TRANSPORT.
- 8.) GEOMETRIC FEATURES NOT DIMENSIONED ARE CONTROLLED BY 3D MODEL.

THE INFORMATION CONTAINED IN THIS DRAWING IS THE SOLE PROPERTY OF RYADON INC. ANY REPRODUCTION IN PART OR AS A WHOLE WITHOUT THE WRITTEN PERMISSION OF RYADON INC. IS PROHIBITED.

REVISIONS			DEPT.	NAME	DATE
REV.	DESCRIPTION	DATE	SALES	MB	06/28/18
1	INITIAL RELEASE	06/28/18	ENG.	NS	06/28/18
			Q.A.	PN	06/28/18
TOLERANCES UNLESS OTHERWISE SPECIFIED: .X = ± .05 .XX = ± .03 .XXX = ± .015 .XXXX = ± .008 X/X = ± 1/32" ANGLE = ± 1° SURFACE = ±			RYADON INC. DESCRIPTION: 2250 SERIES 18" SLIDE MATERIAL: STEEL FINISH: ZINC PLATED SIZE A PART No. I-DS-2250-18-QD SCALE: NTS SHEET 1 OF 1 DRAWN BY/DATE NAS 06/28/18		

REV 1

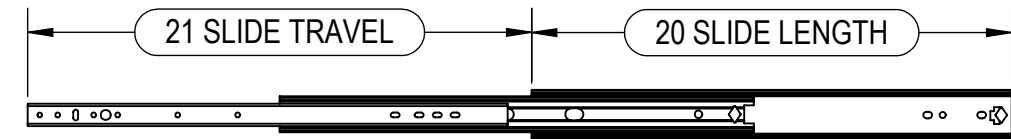
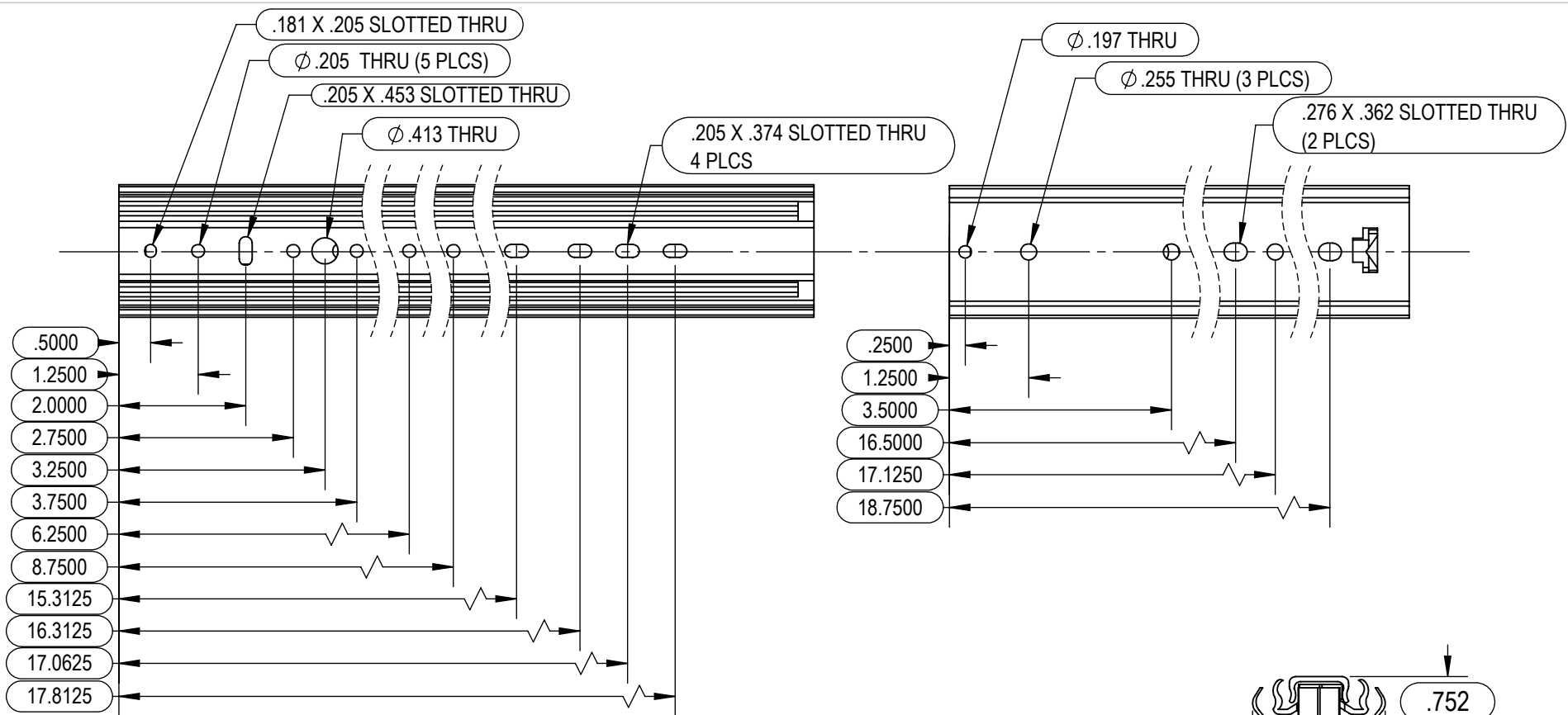

RECOMMENDED
INNER SLIDE MEMBER:
#10 MACHINE OR WOOD PAN HEAD SCREW FOR ALL THRU HOLES AND SLOTTED THRU HOLES

OUTER SLIDE MEMBER:
1/4 HEX BOLT, #14 PAN HEAD WOOD SCREW FOR ALL THRU HOLES AND SLOTTED THRU HOLES

SIDE SPACE:
.753" - .780"

- NOTES:**
- DO NOT SCALE DRAWING.
 - REMOVE ALL BURRS, NO SHARP EDGES.
 - MUST NOT HAVE SCRATCHES, DINGS, OR DENTS.
 - PART TO BE FREE FROM SURFACE IMPERFECTIONS OTHER THAN SURFACE FINISH REQUIREMENTS.
 - CRITICAL DIMENSIONS ARE INDICATED BY:
 - ALL ITEMS ARE TO BE INSPECTED TO 2.5 AQL SAMPLING PLAN UNLESS OTHERWISE STATED.
 - ENSURE PACKAGING WILL PROVIDE ADEQUATE PROTECTION DURING TRANSPORT.
 - GEOMETRIC FEATURES NOT DIMENSIONED ARE CONTROLLED BY 3D MODEL.

REVISIONS			DEPT.	NAME	DATE
REV.	DESCRIPTION	DATE	SALES	MB	06/28/18
1	INITIAL RELEASE	06/28/18	ENG.	NS	06/28/18
			Q.A.	PN	06/28/18

TOLERANCES UNLESS OTHERWISE SPECIFIED:		DESCRIPTION: 2250 SERIES 20" SLIDE	RYADON INC.	
.X = ± .05	.XX = ± .03			
.XXX = ± .015	.XXXX = ± .008	MATERIAL: STEEL	SIZE A	PART No. I-DS-2250-20-QD
.X/X = ± 1/32"	ANGLE = ± 1°	FINISH: ZINC PLATED	SCALE: NTS	SHEET 1 OF 1
SURFACE = ±				DRAWN BY/DATE NAS 06/28/18

THE INFORMATION CONTAINED IN THIS DRAWING IS THE SOLE PROPERTY OF RYADON INC. ANY REPRODUCTION IN PART OR AS A WHOLE WITHOUT THE WRITTEN PERMISSION OF RYADON INC. IS PROHIBITED.

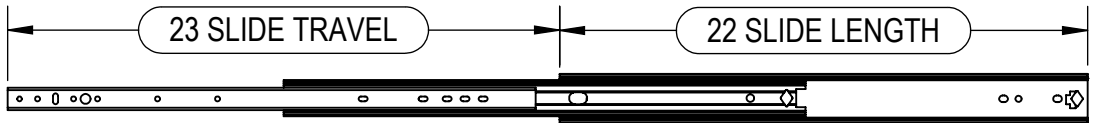
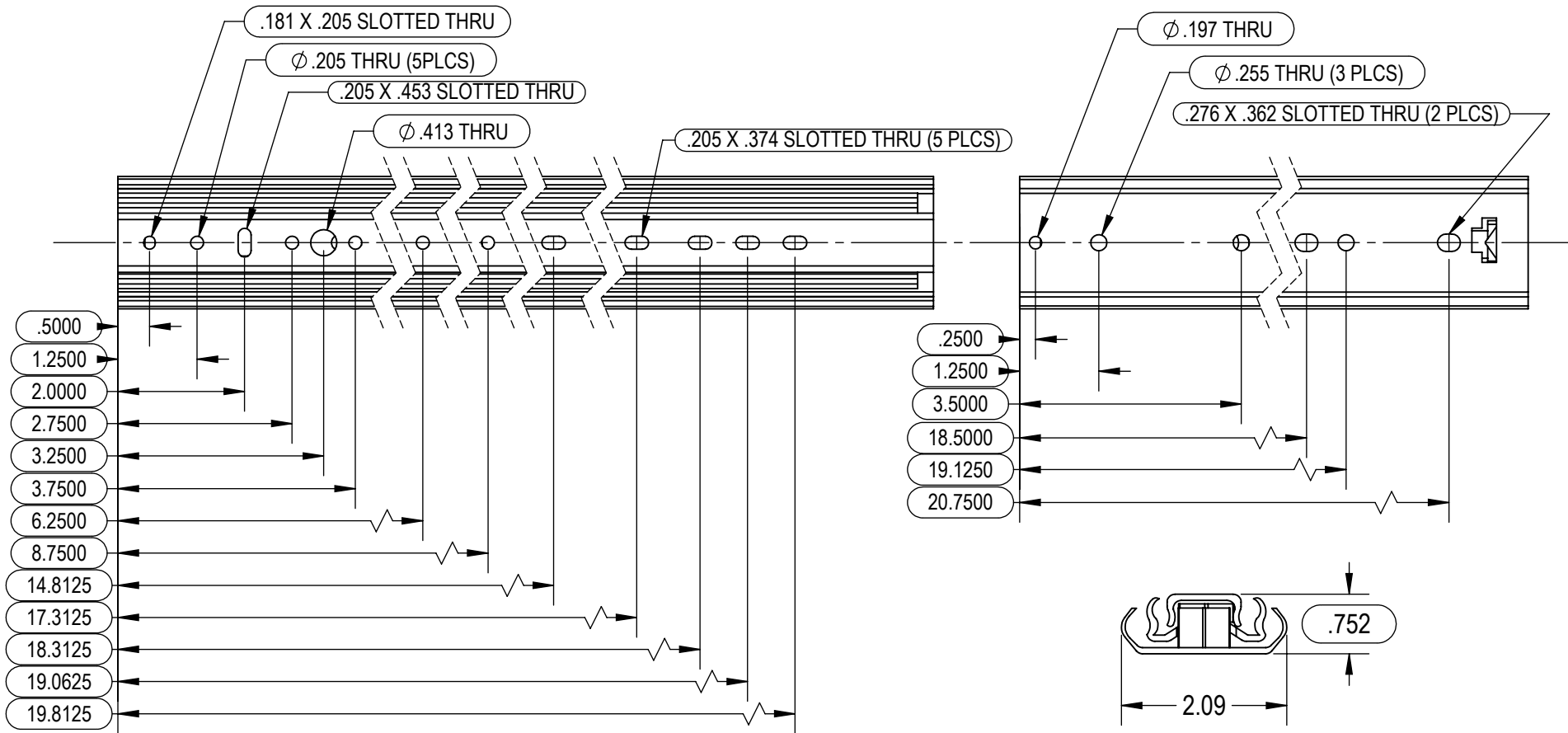

RECOMMENDED
 INNER SLIDE MEMBER:
 #10 MACHINE OR WOOD PAN HEAD SCREW FOR ALL THRU HOLES AND SLOTTED THRU HOLES

OUTER SLIDE MEMBER:
 1/4 HEX BOLT, #14 PAN HEAD WOOD SCREW FOR ALL THRU HOLES AND SLOTTED THRU HOLES

SIDE SPACE:
 .753" - .780"

- NOTES:**
- DO NOT SCALE DRAWING.
 - REMOVE ALL BURRS, NO SHARP EDGES.
 - MUST NOT HAVE SCRATCHES, DINGS, OR DENTS.
 - PART TO BE FREE FROM SURFACE IMPERFECTIONS OTHER THAN SURFACE FINISH REQUIREMENTS.
 - CRITICAL DIMENSIONS ARE INDICATED BY:
 - ALL ITEMS ARE TO BE INSPECTED TO 2.5 AQL SAMPLING PLAN UNLESS OTHERWISE STATED.
 - ENSURE PACKAGING WILL PROVIDE ADEQUATE PROTECTION DURING TRANSPORT.
 - GEOMETRIC FEATURES NOT DIMENSIONED ARE CONTROLLED BY 3D MODEL.

REVISIONS			DEPT.	NAME	DATE
REV.	DESCRIPTION	DATE	SALES	MB	06/28/18
1	INITIAL RELEASE	06/28/18	ENG.	NS	06/28/18
			Q.A.	PN	06/28/18

TOLERANCES UNLESS OTHERWISE SPECIFIED: .X = ± .05 .XX = ± .03 .XXX = ± .015 .XXXX = ± .008 X/X = ± 1/32" ANGLE = ± 1° SURFACE = ±		DESCRIPTION: 2250 SERIES 22" SLIDE	RYADON INC.
MATERIAL:	STEEL	SIZE A PART No. I-DS-2250-22-QD REV 1	
FINISH:	ZINC PLATED	SCALE: NTS SHEET 1 OF 1 DRAWN BY/DATE NAS 06/28/18	

THE INFORMATION CONTAINED IN THIS DRAWING IS THE SOLE PROPERTY OF RYADON INC. ANY REPRODUCTION IN PART OR AS A WHOLE WITHOUT THE WRITTEN PERMISSION OF RYADON INC. IS PROHIBITED.

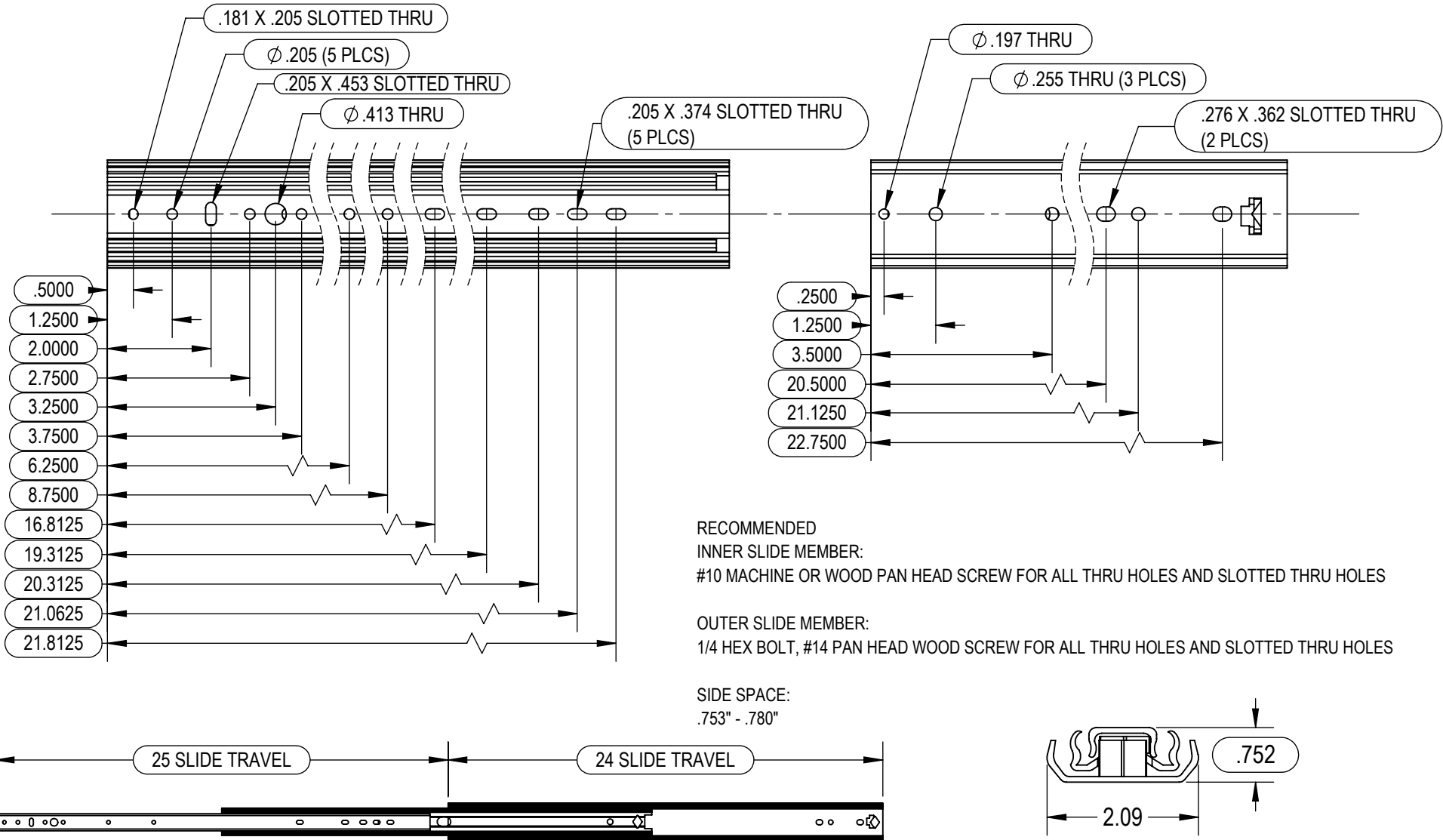

RECOMMENDED
INNER SLIDE MEMBER:
#10 MACHINE OR WOOD PAN HEAD SCREW FOR ALL THRU HOLES AND SLOTTED THRU HOLES

OUTER SLIDE MEMBER:
1/4 HEX BOLT, #14 PAN HEAD WOOD SCREW FOR ALL THRU HOLES AND SLOTTED THRU HOLES

SIDE SPACE:
.753" - .780"

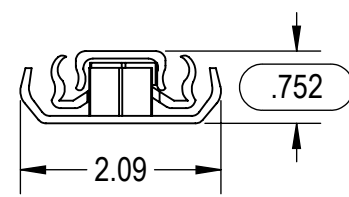

- NOTES:**
- 1.) DO NOT SCALE DRAWING.
 - 2.) REMOVE ALL BURRS, NO SHARP EDGES.
 - 3.) MUST NOT HAVE SCRATCHES, DINGS, OR DENTS.
 - 4.) PART TO BE FREE FROM SURFACE IMPERFECTIONS OTHER THAN SURFACE FINISH REQUIREMENTS.
 - 5.) CRITICAL DIMENSIONS ARE INDICATED BY:
 - 6.) ALL ITEMS ARE TO BE INSPECTED TO 2.5 AQL SAMPLING PLAN UNLESS OTHERWISE STATED.
 - 7.) ENSURE PACKAGING WILL PROVIDE ADEQUATE PROTECTION DURING TRANSPORT.
 - 8.) GEOMETRIC FEATURES NOT DIMENSIONED ARE CONTROLLED BY 3D MODEL.

THE INFORMATION CONTAINED IN THIS DRAWING IS THE SOLE PROPERTY OF RYADON INC. ANY REPRODUCTION IN PART OR AS A WHOLE WITHOUT THE WRITTEN PERMISSION OF RYADON INC. IS PROHIBITED.

REVISIONS			DEPT.	NAME	DATE
REV.	DESCRIPTION	DATE	SALES	MB	06/28/18
1	INITIAL RELEASE	06/28/18	ENG.	NS	06/28/18
			Q.A.	PN	06/28/18

TOLERANCES UNLESS OTHERWISE SPECIFIED:		DESCRIPTION:		RYADON INC.	
X = ± .05 .XX = ± .03 .XXX = ± .015 .XXX = ± .008 X/X = ± 1/32" ANGLE = ± 1° SURFACE = ±		2250 SERIES 24" SLIDE			
MATERIAL:		SIZE	PART No.	REV	
STEEL		A	I-DS-2250-24-QD	1	
FINISH:		SCALE:	SHEET 1 OF 1	DRAWN BY/DATE	
ZINC PLATED		NTS		NAS 06/28/18	

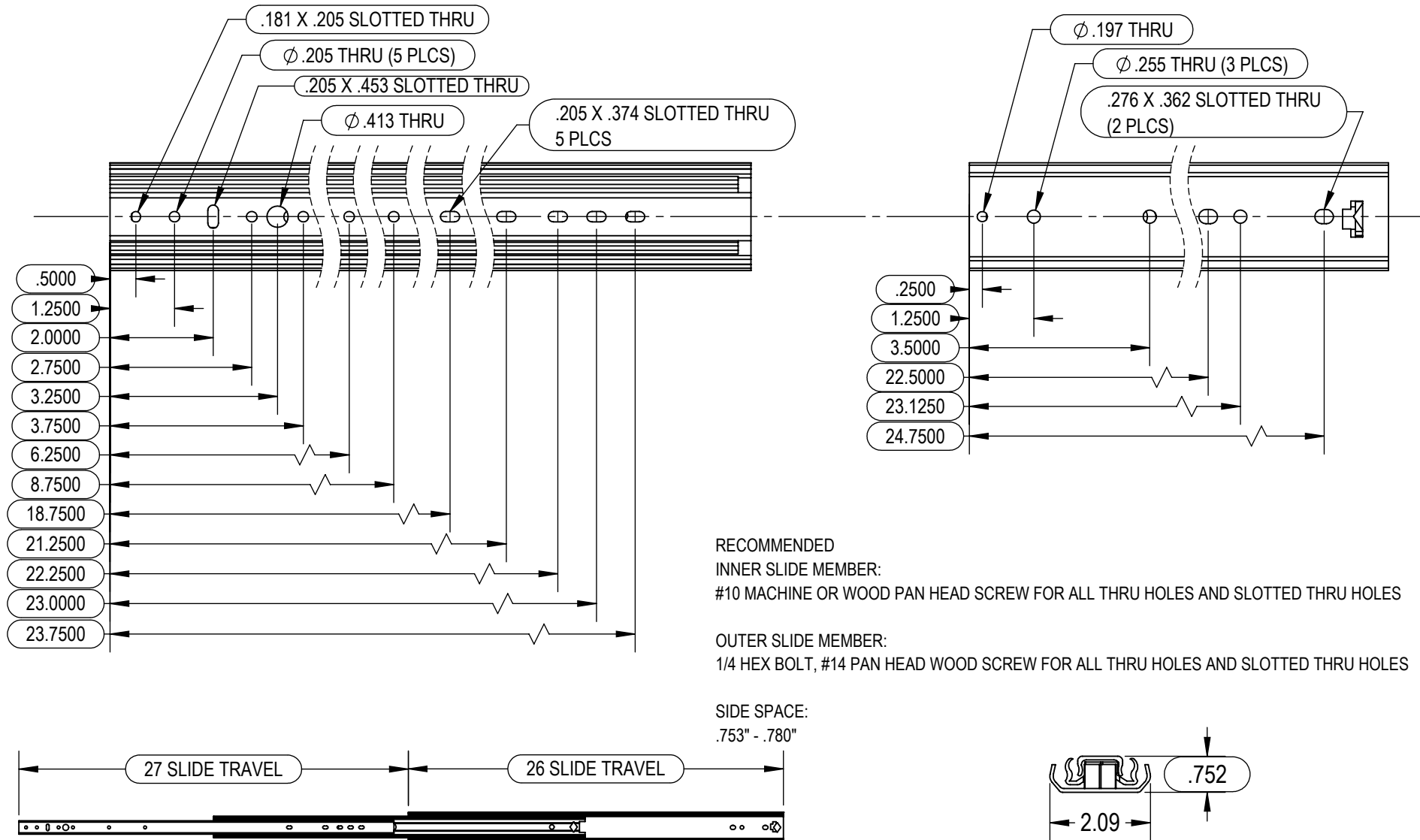

RECOMMENDED
INNER SLIDE MEMBER:
#10 MACHINE OR WOOD PAN HEAD SCREW FOR ALL THRU HOLES AND SLOTTED THRU HOLES

OUTER SLIDE MEMBER:
1/4 HEX BOLT, #14 PAN HEAD WOOD SCREW FOR ALL THRU HOLES AND SLOTTED THRU HOLES

NOTES:

- DO NOT SCALE DRAWING.
- REMOVE ALL BURRS, NO SHARP EDGES.
- MUST NOT HAVE SCRATCHES, DINGS, OR DENTS.
- PART TO BE FREE FROM SURFACE IMPERFECTIONS OTHER THAN SURFACE FINISH REQUIREMENTS.
- CRITICAL DIMENSIONS ARE INDICATED BY:
- ALL ITEMS ARE TO BE INSPECTED TO 2.5 AQL SAMPLING PLAN UNLESS OTHERWISE STATED.
- ENSURE PACKAGING WILL PROVIDE ADEQUATE PROTECTION DURING TRANSPORT.
- GEOMETRIC FEATURES NOT DIMENSIONED ARE CONTROLLED BY 3D MODEL.

THE INFORMATION CONTAINED IN THIS DRAWING IS THE SOLE PROPERTY OF RYADON INC. ANY REPRODUCTION IN PART OR AS A WHOLE WITHOUT THE WRITTEN PERMISSION OF RYADON INC. IS PROHIBITED.

REVISIONS			DEPT.	NAME	DATE
REV.	DESCRIPTION	DATE	SALES	MB	06/28/18
1	INITIAL RELEASE	06/28/18	ENG.	NS	06/28/18
			Q.A.	PN	06/28/18
TOLERANCES UNLESS OTHERWISE SPECIFIED: .X = ± .05 .XX = ± .03 .XXX = ± .015 .XXXX = ± .008 X/X = ± 1/32" ANGLE = ± 1° SURFACE = ±			RYADON INC.		
DESCRIPTION: 2250 SERIES 26" SLIDE			SIZE A	PART No. I-DS-2250-26-QD	REV 1
MATERIAL: STEEL			SCALE: NTS		
FINISH: ZINC PLATED			SHEET 1 OF 1		
			DRAWN BY/DATE NAS 06/28/18		

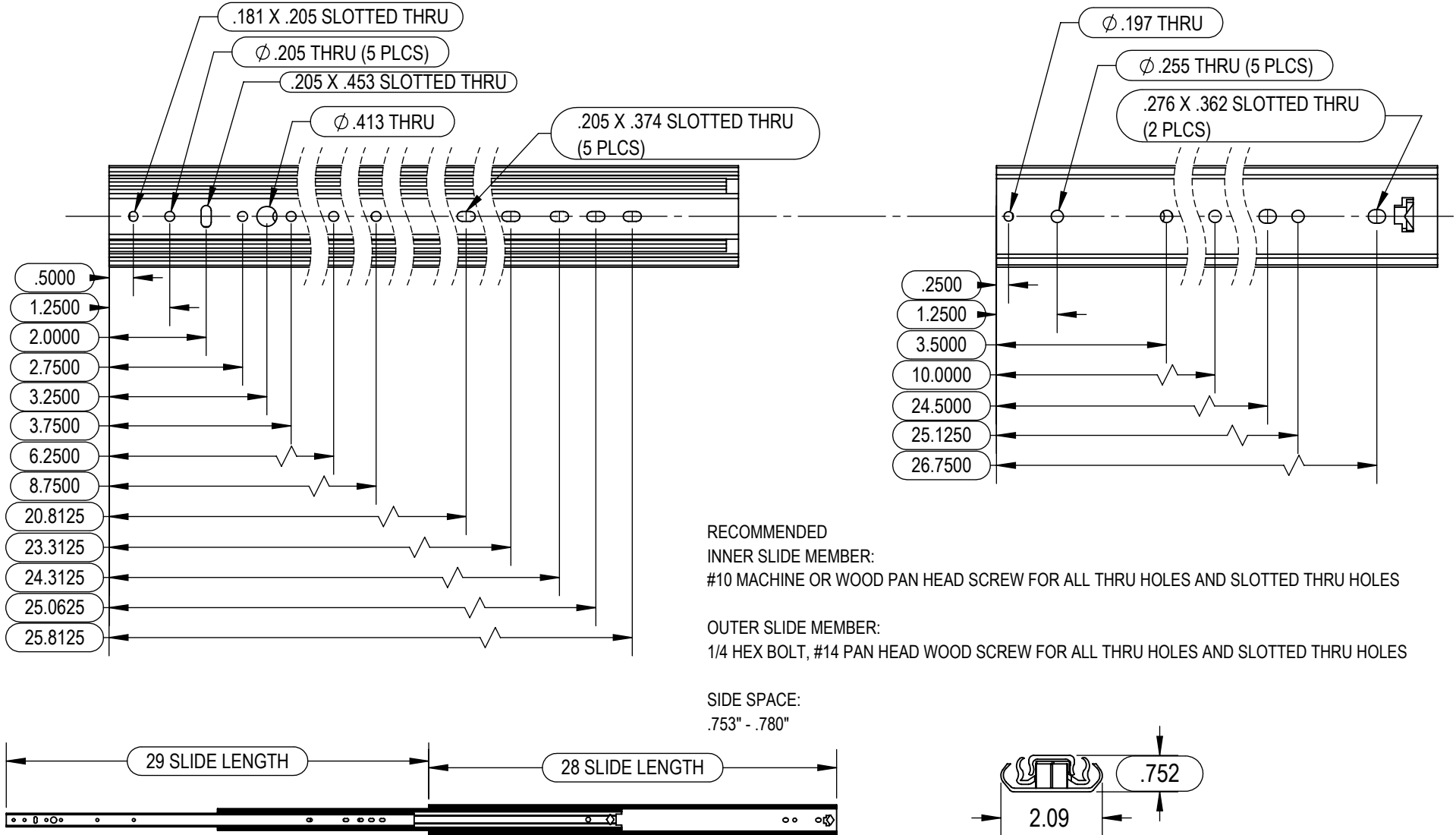

NOTES:

- 1.) DO NOT SCALE DRAWING.
- 2.) REMOVE ALL BURRS, NO SHARP EDGES.
- 3.) MUST NOT HAVE SCRATCHES, DINGS, OR DENTS.
- 4.) PART TO BE FREE FROM SURFACE IMPERFECTIONS OTHER THAN SURFACE FINISH REQUIREMENTS.
- 5.) CRITICAL DIMENSIONS ARE INDICATED BY:
- 6.) ALL ITEMS ARE TO BE INSPECTED TO 2.5 AQL SAMPLING PLAN UNLESS OTHERWISE STATED.
- 7.) ENSURE PACKAGING WILL PROVIDE ADEQUATE PROTECTION DURING TRANSPORT.
- 8.) GEOMETRIC FEATURES NOT DIMENSIONED ARE CONTROLLED BY 3D MODEL.

THE INFORMATION CONTAINED IN THIS DRAWING IS THE SOLE PROPERTY OF RYADON INC. ANY REPRODUCTION IN PART OR AS A WHOLE WITHOUT THE WRITTEN PERMISSION OF RYADON INC. IS PROHIBITED.

REVISIONS			DEPT.	NAME	DATE
REV.	DESCRIPTION	DATE	SALES	MB	06/28/18
1	INITIAL RELEASE	06/28/18	ENG.	NS	06/28/18
			Q.A.	PN	06/28/18
TOLERANCES UNLESS OTHERWISE SPECIFIED: .X = ± .05 .XX = ± .03 .XXX = ± .015 .XXXX = ± .008 X/X = ± 1/32" ANGLE = ± 1° SURFACE = ± $\sqrt{.125}$			RYADON INC.		
DESCRIPTION: 2250 SERIES 28" SLIDE			SIZE A	PART No. I-DS-2250-28-QD	REV 1
MATERIAL: STEEL			SCALE: NTS		
FINISH: ZINC PLATED			SHEET 1 OF 1		
			DRAWN BY/DATE NAS 06/28/18		

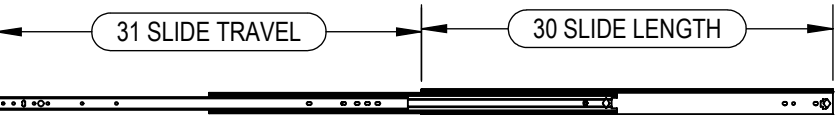
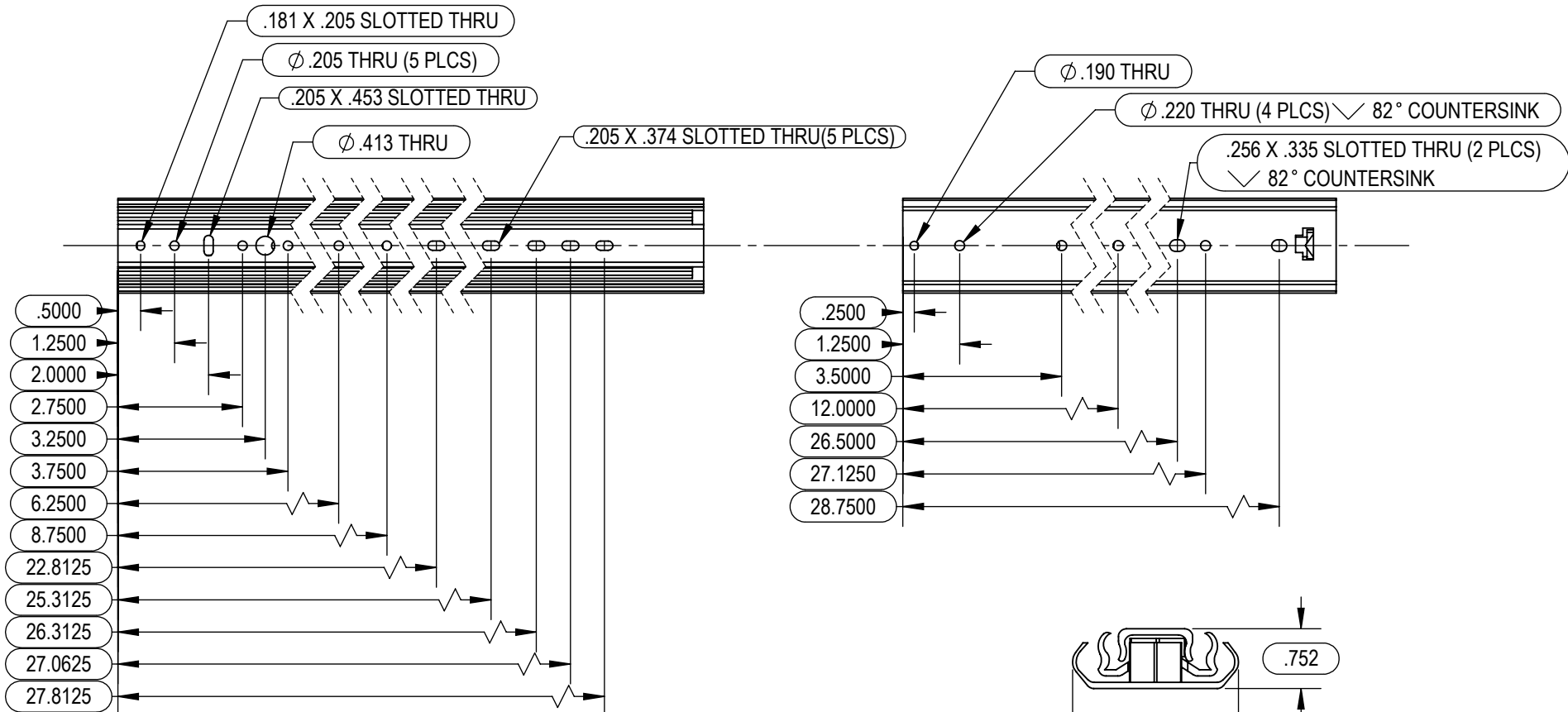

RECOMMENDED
 INNER SLIDE MEMBER:
 #10 MACHINE OR WOOD PAN HEAD SCREW FOR ALL THRU HOLES AND SLOTTED THRU HOLES

OUTER SLIDE MEMBER:
 1/4 HEX BOLT, #14 PAN HEAD WOOD SCREW FOR ALL THRU HOLES AND SLOTTED THRU HOLES

SIDE SPACE:
 .753" - .780"

NOTES:

- 1.) DO NOT SCALE DRAWING.
- 2.) REMOVE ALL BURRS, NO SHARP EDGES.
- 3.) MUST NOT HAVE SCRATCHES, DINGS, OR DENTS.
- 4.) PART TO BE FREE FROM SURFACE IMPERFECTIONS OTHER THAN SURFACE FINISH REQUIREMENTS.
- 5.) CRITICAL DIMENSIONS ARE INDICATED BY:
- 6.) ALL ITEMS ARE TO BE INSPECTED TO 2.5 AQL SAMPLING PLAN UNLESS OTHERWISE STATED.
- 7.) ENSURE PACKAGING WILL PROVIDE ADEQUATE PROTECTION DURING TRANSPORT.
- 8.) GEOMETRIC FEATURES NOT DIMENSIONED ARE CONTROLLED BY 3D MODEL.

THE INFORMATION CONTAINED IN THIS DRAWING IS THE SOLE PROPERTY OF RYADON INC. ANY REPRODUCTION IN PART OR AS A WHOLE WITHOUT THE WRITTEN PERMISSION OF RYADON INC. IS PROHIBITED.

REVISIONS			DEPT.	NAME	DATE
REV.	DESCRIPTION	DATE	SALES	MB	06/28/18
1	INITIAL RELEASE	06/28/18	ENG.	NS	06/28/18
			Q.A.	PN	06/28/18
TOLERANCES UNLESS OTHERWISE SPECIFIED: .X = ± .05 .XX = ± .03 .XXX = ± .015 .XXXX = ± .008 X/X = ± 1/32" ANGLE = ± 1° SURFACE = ± $\sqrt{\quad}$			DESCRIPTION: 2250 SERIES 30" SLIDE MATERIAL: STEEL FINISH: ZINC PLATED		
			RYADON INC.		
		SIZE A	PART No. I-DS-2250-30-QD		REV 1
		SCALE: NTS	SHEET 1 OF 1		DRAWN BY/DATE NAS 06/28/18

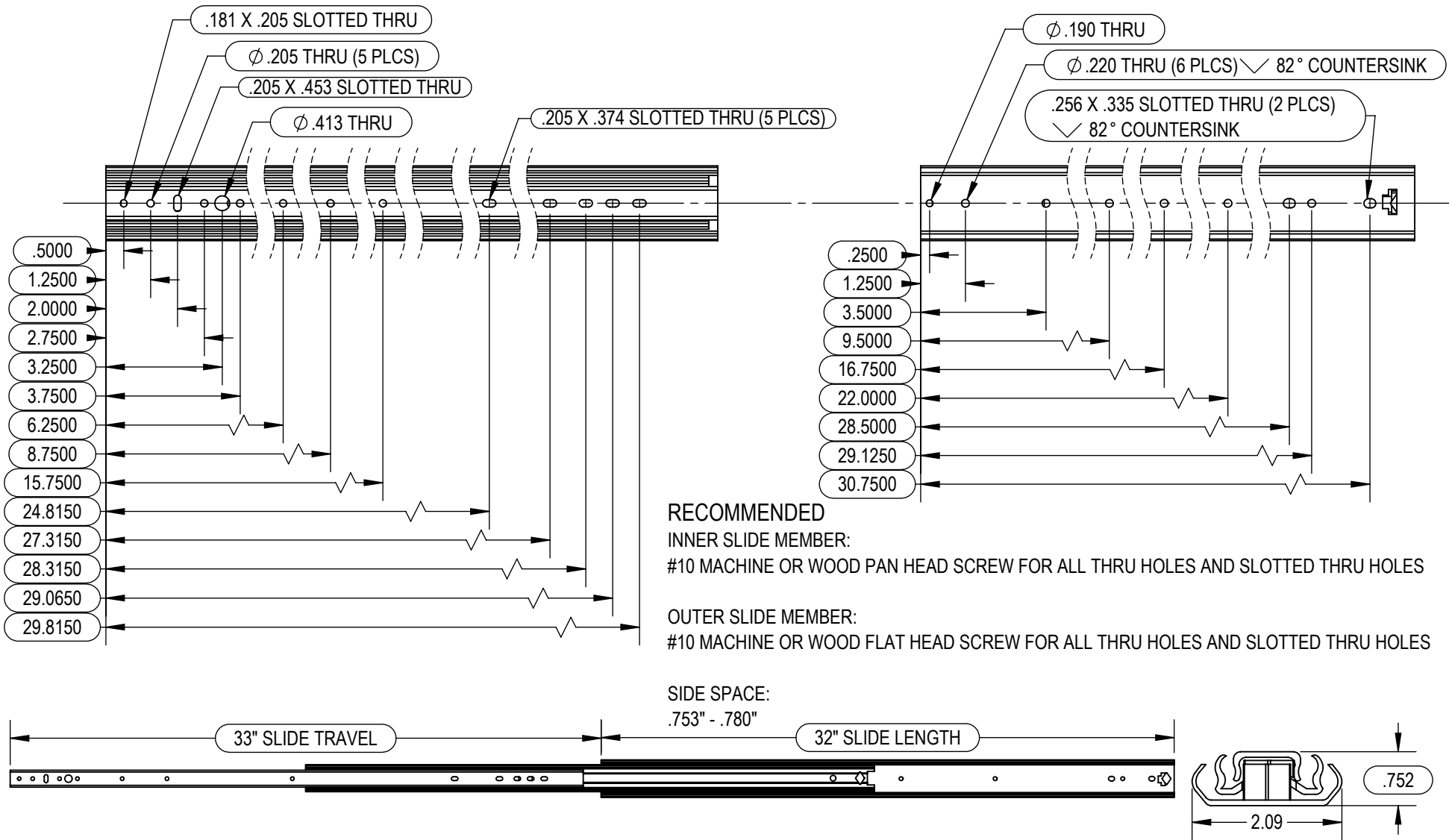

RECOMMENDED
INNER SLIDE MEMBER:
#10 MACHINE OR WOOD PAN HEAD SCREW FOR ALL THRU HOLES AND SLOTTED THRU HOLES

OUTER SLIDE MEMBER:
#10 MACHINE OR WOOD FLAT HEAD SCREW FOR ALL THRU HOLES AND SLOTTED THRU HOLES

SIDE SPACE:
.753" - .780"

NOTES:

- 1.) DO NOT SCALE DRAWING.
- 2.) REMOVE ALL BURRS, NO SHARP EDGES.
- 3.) MUST NOT HAVE SCRATCHES, DINGS, OR DENTS.
- 4.) PART TO BE FREE FROM SURFACE IMPERFECTIONS OTHER THAN SURFACE FINISH REQUIREMENTS.
- 5.) CRITICAL DIMENSIONS ARE INDICATED BY:
- 6.) ALL ITEMS ARE TO BE INSPECTED TO 2.5 AQL SAMPLING PLAN UNLESS OTHERWISE STATED.
- 7.) ENSURE PACKAGING WILL PROVIDE ADEQUATE PROTECTION DURING TRANSPORT.
- 8.) GEOMETRIC FEATURES NOT DIMENSIONED ARE CONTROLLED BY 3D MODEL.

THE INFORMATION CONTAINED IN THIS DRAWING IS THE SOLE PROPERTY OF RYADON INC. ANY REPRODUCTION IN PART OR AS A WHOLE WITHOUT THE WRITTEN PERMISSION OF RYADON INC. IS PROHIBITED.

REVISIONS			DEPT.	NAME	DATE
REV.	DESCRIPTION	DATE	SALES	MB	06/28/18
1	INITIAL RELEASE	06/28/18	ENG.	NS	06/28/18
			Q.A.	PN	06/28/18
TOLERANCES UNLESS OTHERWISE SPECIFIED: .X = ± .05 .XX = ± .03 .XXX = ± .015 .XXXX = ± .008 X/X = ± 1/32" ANGLE = ± 1° SURFACE = ± $\sqrt{.125}$			RYADON INC.		
DESCRIPTION: 2250 SERIES 32" SLIDE			SIZE A	PART No. I-DS-2250-32-QD	REV 1
MATERIAL: STEEL			SCALE: NTS		
FINISH: ZINC PLATED			SHEET 1 OF 1		
			DRAWN BY/DATE NAS 06/28/18		

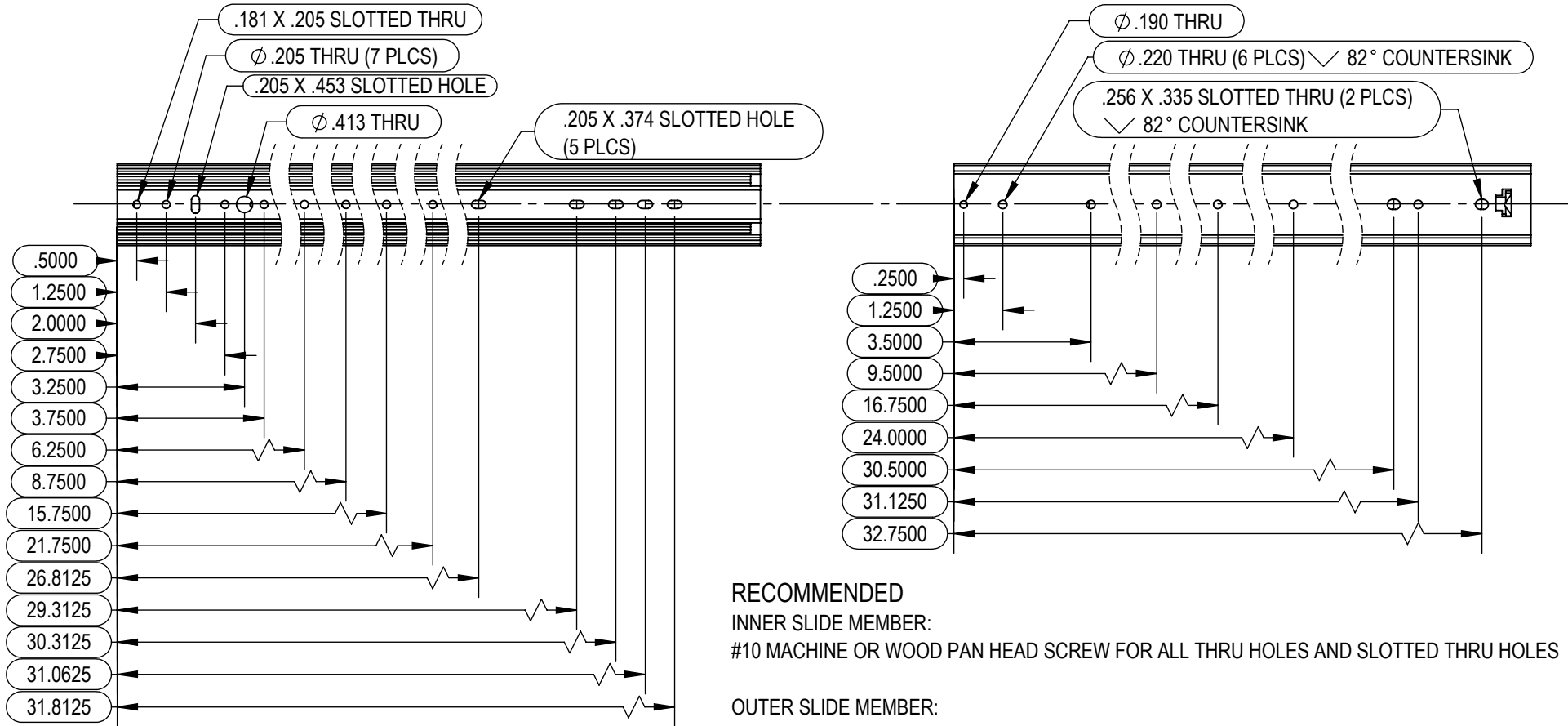

RECOMMENDED

INNER SLIDE MEMBER:

#10 MACHINE OR WOOD PAN HEAD SCREW FOR ALL THRU HOLES AND SLOTTED THRU HOLES

OUTER SLIDE MEMBER:

#10 MACHINE OR WOOD FLAT HEAD SCREW FOR ALL THRU HOLES AND SLOTTED THRU HOLES

SIDE SPACE:

.753" -.780"

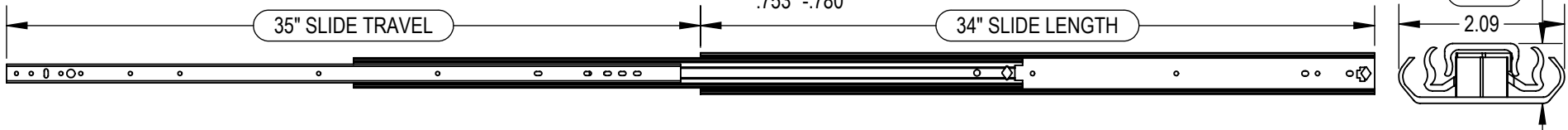

NOTES:

- 1.) DO NOT SCALE DRAWING.
- 2.) REMOVE ALL BURRS, NO SHARP EDGES.
- 3.) MUST NOT HAVE SCRATCHES, DINGS, OR DENTS.
- 4.) PART TO BE FREE FROM SURFACE IMPERFECTIONS OTHER THAN SURFACE FINISH REQUIREMENTS.
- 5.) CRITICAL DIMENSIONS ARE INDICATED BY:
- 6.) ALL ITEMS ARE TO BE INSPECTED TO 2.5 AQL SAMPLING PLAN UNLESS OTHERWISE STATED.
- 7.) ENSURE PACKAGING WILL PROVIDE ADEQUATE PROTECTION DURING TRANSPORT.
- 8.) GEOMETRIC FEATURES NOT DIMENSIONED ARE CONTROLLED BY 3D MODEL.

THE INFORMATION CONTAINED IN THIS DRAWING IS THE SOLE PROPERTY OF RYADON INC. ANY REPRODUCTION IN PART OR AS A WHOLE WITHOUT THE WRITTEN PERMISSION OF RYADON INC. IS PROHIBITED.

REVISIONS			DEPT.	NAME	DATE
REV.	DESCRIPTION	DATE	SALES	MB	06/28/18
1	INITIAL RELEASE	06/28/18	ENG.	NS	06/28/18
			Q.A.	PN	06/28/18
TOLERANCES UNLESS OTHERWISE SPECIFIED: .X = ± .05 .XX = ± .03 .XXX = ± .015 .XXXX = ± .008 X/X = ± 1/32" ANGLE = ± 1° SURFACE = ±			RYADON INC.		
DESCRIPTION: 2250 SERIES 34" SLIDE			SIZE A	PART No. I-DS-2250-34-QD	REV 1
MATERIAL: STEEL			SCALE: NTS		
FINISH: ZINC PLATED			SHEET 1 OF 1		
			DRAWN BY/DATE NAS 06/28/18		

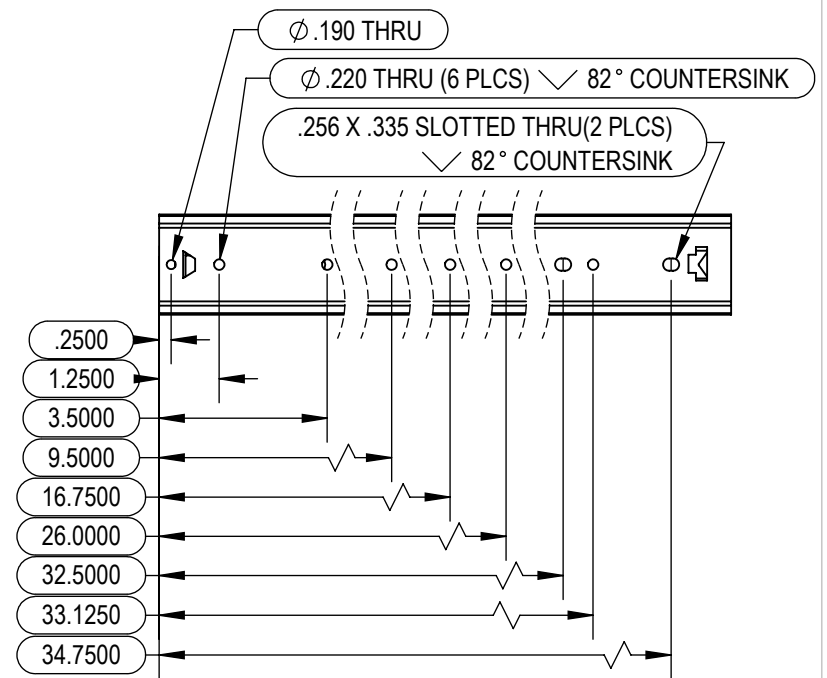
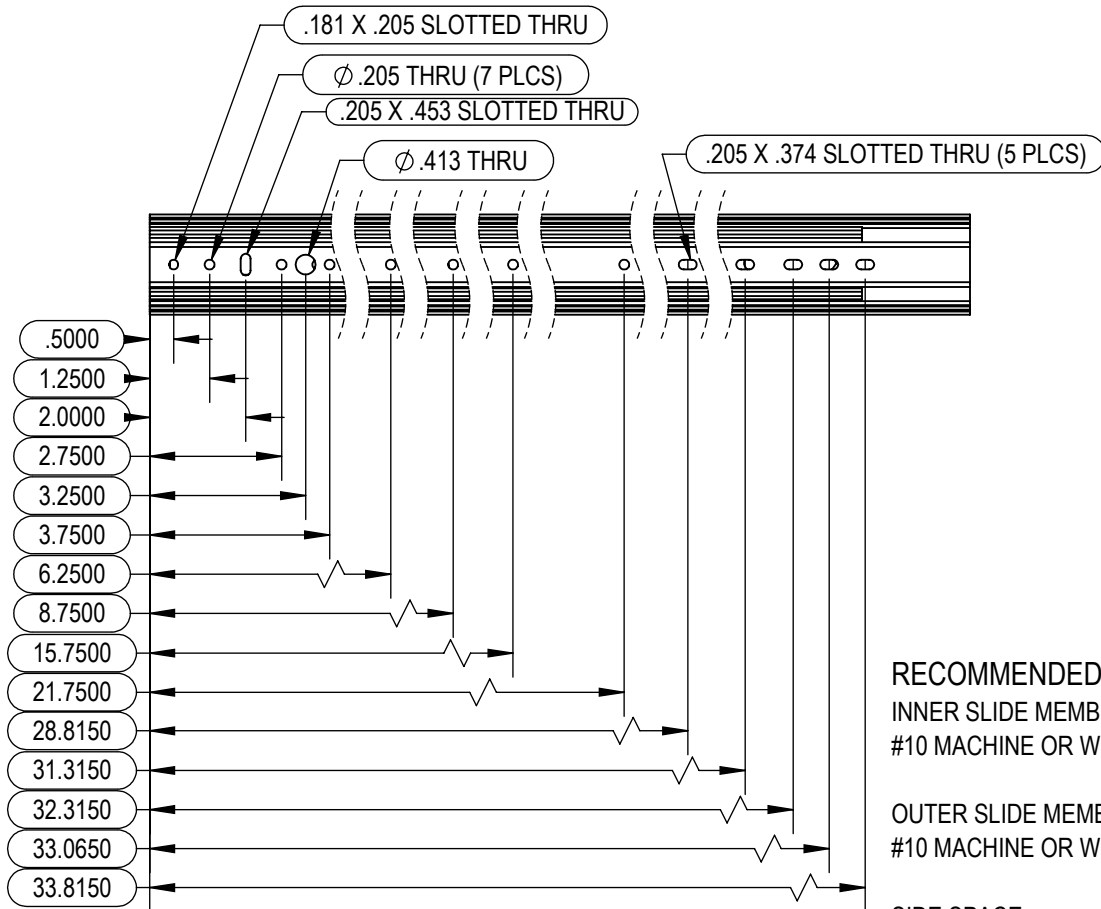

RECOMMENDED

INNER SLIDE MEMBER:

#10 MACHINE OR WOOD PAN HEAD SCREW FOR ALL THRU HOLES AND SLOTTED THRU HOLES

OUTER SLIDE MEMBER:

#10 MACHINE OR WOOD FLAT HEAD SCREW FOR ALL THRU HOLES AND SLOTTED THRU HOLES

SIDE SPACE:

.753" - .780"

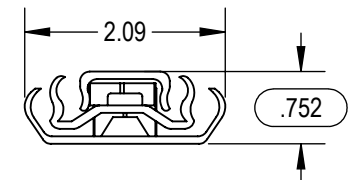
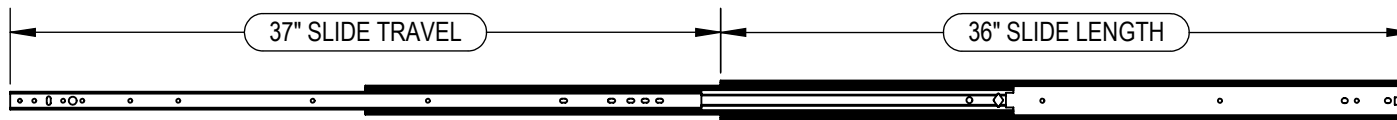

NOTES:

- 1.) DO NOT SCALE DRAWING.
- 2.) REMOVE ALL BURRS, NO SHARP EDGES.
- 3.) MUST NOT HAVE SCRATCHES, DINGS, OR DENTS.
- 4.) PART TO BE FREE FROM SURFACE IMPERFECTIONS OTHER THAN SURFACE FINISH REQUIREMENTS.
- 5.) CRITICAL DIMENSIONS ARE INDICATED BY:
- 6.) ALL ITEMS ARE TO BE INSPECTED TO 2.5 AQL SAMPLING PLAN UNLESS OTHERWISE STATED.
- 7.) ENSURE PACKAGING WILL PROVIDE ADEQUATE PROTECTION DURING TRANSPORT.
- 8.) GEOMETRIC FEATURES NOT DIMENSIONED ARE CONTROLLED BY 3D MODEL.

THE INFORMATION CONTAINED IN THIS DRAWING IS THE SOLE PROPERTY OF RYADON INC. ANY REPRODUCTION IN PART OR AS A WHOLE WITHOUT THE WRITTEN PERMISSION OF RYADON INC. IS PROHIBITED.

REVISIONS			DEPT.	NAME	DATE
REV.	DESCRIPTION	DATE	SALES	MB	6/26/18
1	INITIAL RELEASE	06/26/18	ENG.	NS	6/26/18
			Q.A.	PN	6/26/18
TOLERANCES UNLESS OTHERWISE SPECIFIED: .X = ± .05 .XX = ± .03 .XXX = ± .015 .XXXX = ± .008 X/X = ± 1/32" ANGLE = ± 1° SURFACE = ±			RYADON INC.		
DESCRIPTION: 2250 SERIES 36" SLIDE			SIZE A	PART No. I-DS-2250-36-QD	REV 1
MATERIAL: STEEL			SCALE: NTS		
FINISH: ZINC PLATED			SHEET 1 OF 1		
			DRAWN BY/DATE NAS 06/26/18		