

6

5

4

3

2

1

D

D

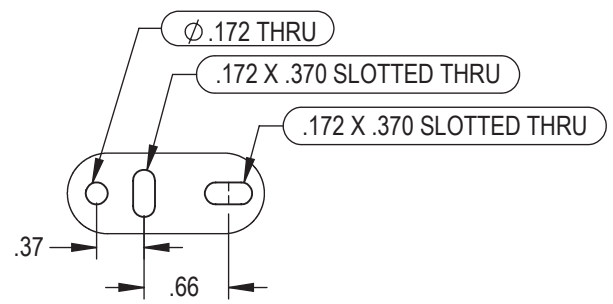
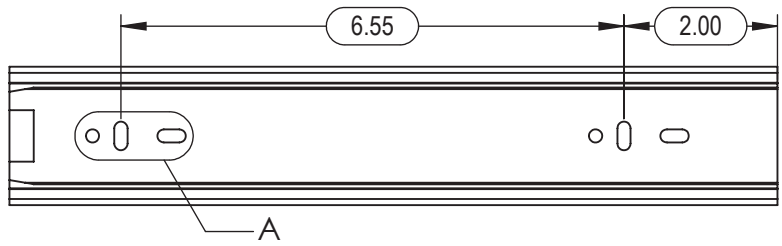

DETAIL A
SCALE 2 : 3

C

C

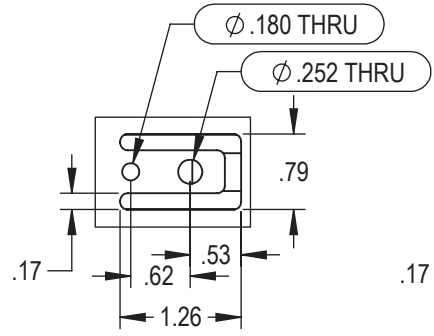
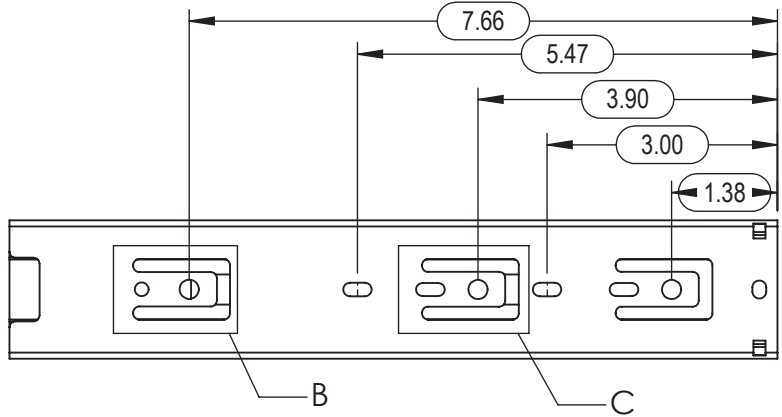

DETAIL B
SCALE 1 : 2

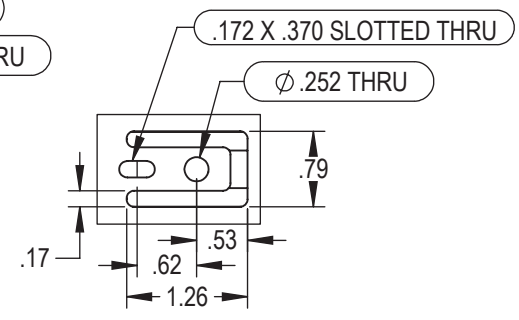

DETAIL C
SCALE 1 : 2

B

B

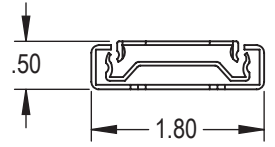
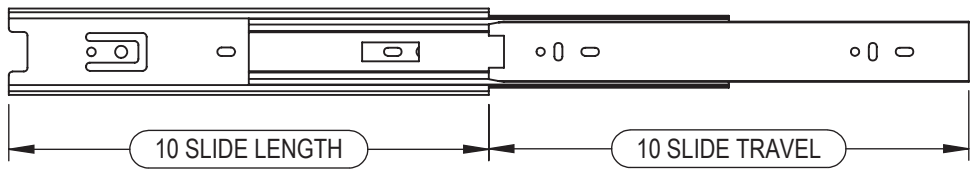

NOTES:

- 1) DO NOT SCALE DRAWING.
- 2) REMOVE ALL BURRS, NO SHARP EDGES.
- 3) MUST NOT HAVE SCRATCHES, DINGS, OR DENTS.
- 4) PART TO BE FREE FROM SURFACE IMPERFECTIONS OTHER THAN SURFACE FINISH REQUIREMENTS.
- 5) CRITICAL DIMENSIONS ARE INDICATED BY:
- 6) ALL ITEMS ARE TO BE INSPECTED TO 2.5 AQL SAMPLING PLAN UNLESS OTHER WISE STATED.
- 7) ENSURE PACKAGING WILL PROVIDE ADEQUATE PROTECTION DURING TRANSPORT.
- 8) GEOMETRIC FEATURES NOT DIMENSIONED ARE CONTROLLED BY 3D MODEL.

DEPT.	NAME	DATE
SALES		
ENG.		
Q.A.		

A

A

REVISIONS		
REV.	DESCRIPTION	DATE
A	INITIAL RELEASE	4/6/16

THE INFORMATION CONTAINED IN THIS DRAWING IS THE SOLE PROPERTY OF RYADON INC. ANY REPRODUCTION IN PART OR AS A WHOLE WITHOUT THE WRITTEN PERMISSION OF RYADON INC. IS PROHIBITED.

TOLERANCES UNLESS OTHERWISE SPECIFIED: .X = ± .05 .XX = ± .03 .XXX = ± .015 XX = ± 1/32" ANGLE = ± 1° SURFACE = ± √	DESCRIPTION: 5632 SERIES 10" SLIDE MATERIAL: STEEL FINISH: ZINC PLATED
---	--

RYADON INC. 

PART No. I-DS-5632-10 REV A

SHEET 1 OF 1 SCALE: NTS SIZE A DRAWN BY/DATE: KAS 4/6/16

6

5

4

3

2

1

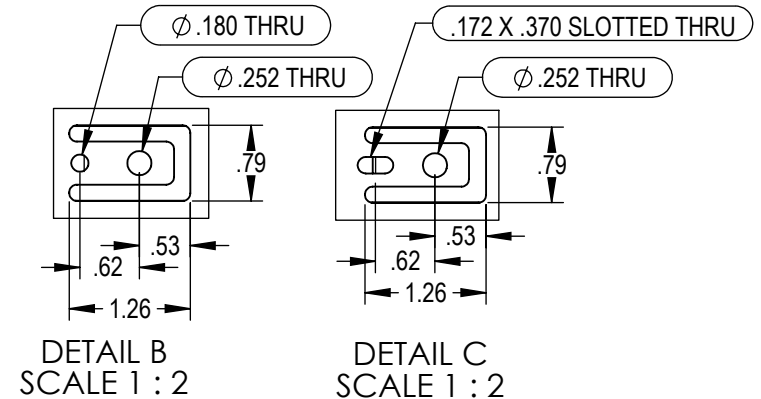
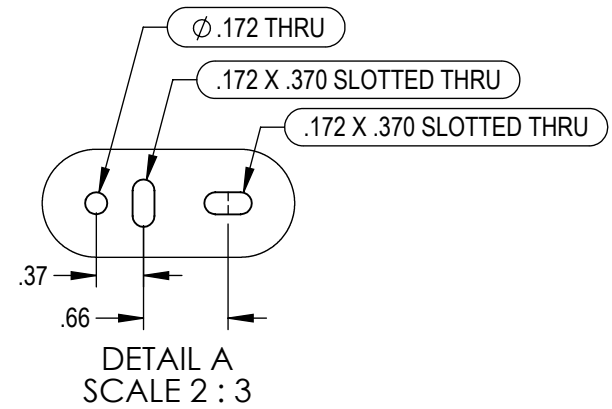
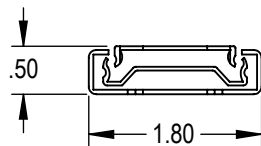
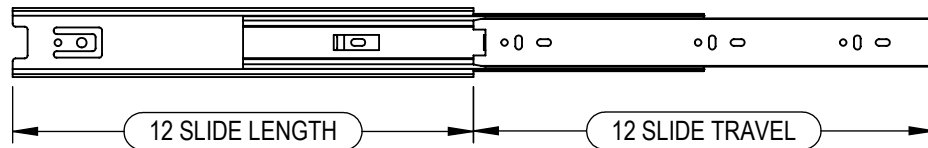
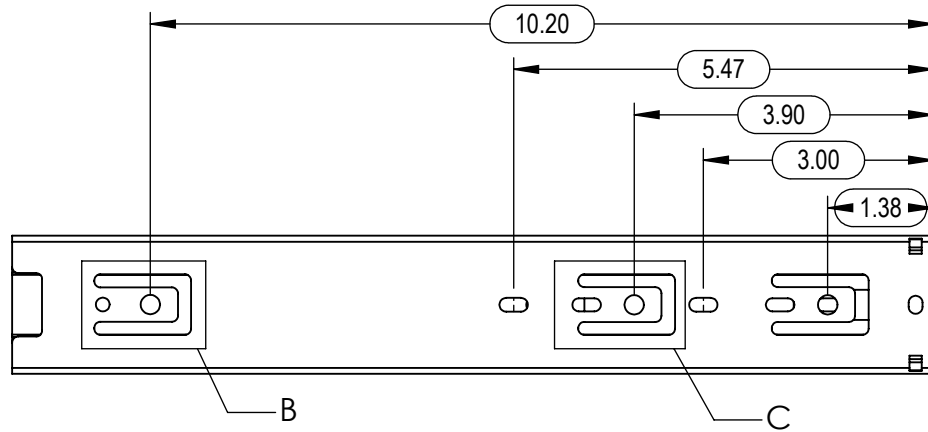
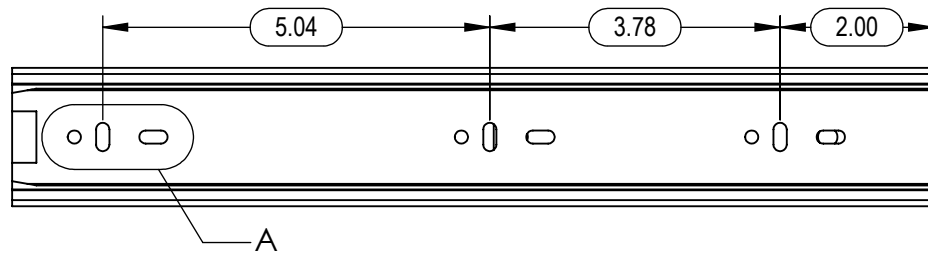

NOTES:

- 1) DO NOT SCALE DRAWING.
- 2) REMOVE ALL BURRS, NO SHARP EDGES.
- 3) MUST NOT HAVE SCRATCHES, DINGS, OR DENTS.
- 4) PART TO BE FREE FROM SURFACE IMPERFECTIONS OTHER THAN SURFACE FINISH REQUIREMENTS.
- 5) CRITICAL DIMENSIONS ARE INDICATED BY .
- 6) ALL ITEMS ARE TO BE INSPECTED TO 2.5 AQL SAMPLING PLAN UNLESS OTHERWISE STATED.
- 7) ENSURE PACKAGING WILL PROVIDE ADEQUATE PROTECTION DURING TRANSPORT.
- 8) GEOMETRIC FEATURES NOT DIMENSIONED ARE CONTROLLED BY 3D MODEL.

DEPT.	NAME	DATE
SALES		
ENG.		
Q.A.		

REVISIONS

REV.	DESCRIPTION	DATE
A	INITIAL RELEASE	4/6/16

THE INFORMATION CONTAINED IN THIS DRAWING IS THE SOLE PROPERTY OF RYADON INC. ANY REPRODUCTION IN PART OR AS A WHOLE WITHOUT THE WRITTEN PERMISSION OF RYADON INC. IS PROHIBITED.

TOLERANCES UNLESS OTHERWISE SPECIFIED:
.X = ± .05
.XX = ± .03
.XXX = ± .015
XX = ± 1/32"
ANGLE = ± 1°
SURFACE = ±

DESCRIPTION:
5632 SERIES
12" SLIDE
 MATERIAL:
STEEL
 FINISH:
ZINC PLATED

RYADON INC.

PART No. **I-DS-5632-12**

REV
A

SHEET 1 OF 1 | SCALE: NTS | SIZE A | DRAWN BY/DATE: KAS 4/6/16

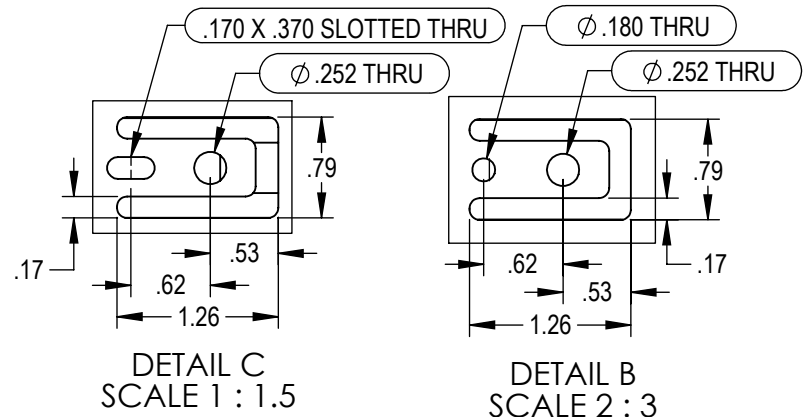
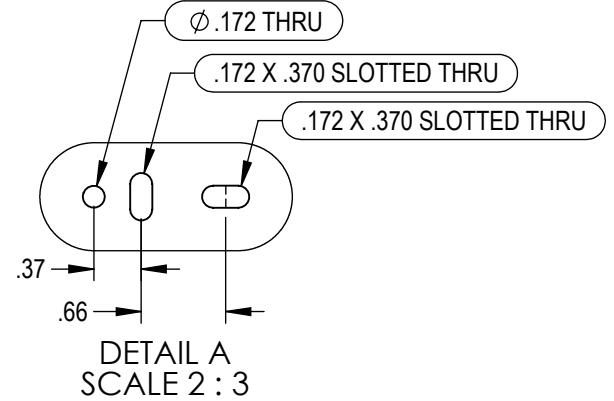
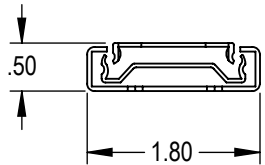
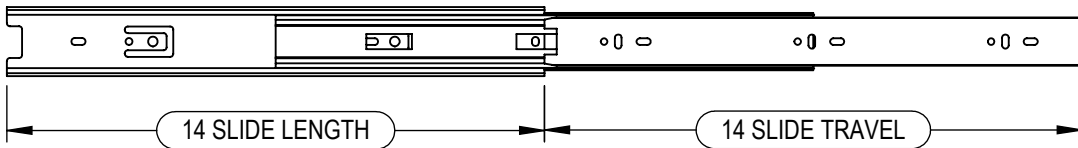
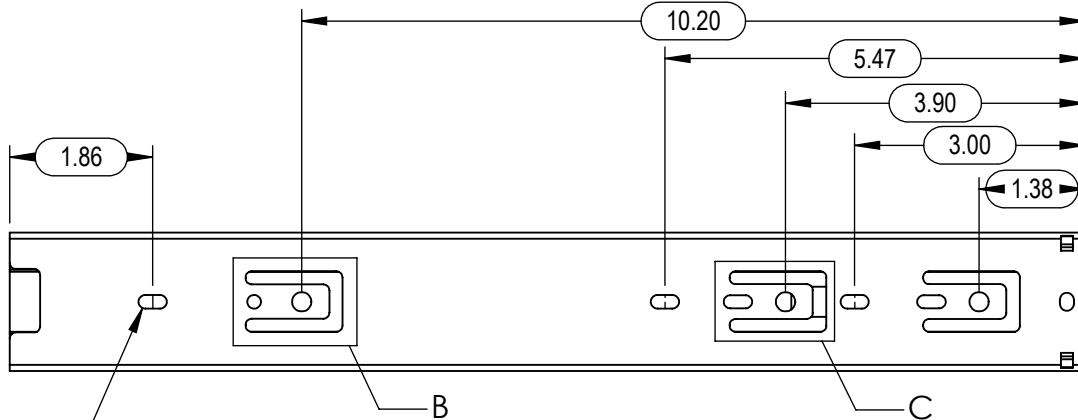
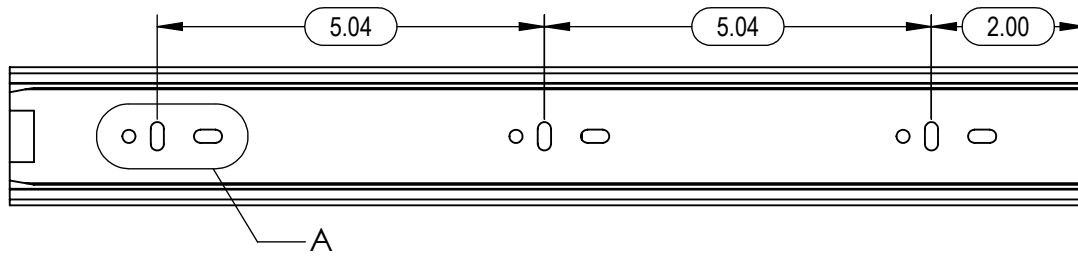

- NOTES:**
- DO NOT SCALE DRAWING.
 - REMOVE ALL BURRS, NO SHARP EDGES.
 - MUST NOT HAVE SCRATCHES, DINGS, OR DENTS.
 - PART TO BE FREE FROM SURFACE IMPERFECTIONS OTHER THAN SURFACE FINISH REQUIREMENTS.
 - CRITICAL DIMENSIONS ARE INDICATED BY:
 - ALL ITEMS ARE TO BE INSPECTED TO 2.5 AQL SAMPLING PLAN UNLESS OTHERWISE STATED.
 - ENSURE PACKAGING WILL PROVIDE ADEQUATE PROTECTION DURING TRANSPORT.
 - GEOMETRIC FEATURES NOT DIMENSIONED ARE CONTROLLED BY 3D MODEL.

DEPT.	NAME	DATE
SALES		
ENG.		
Q.A.		

REV.	DESCRIPTION	DATE
A	INITIAL RELEASE	4/6/16

THE INFORMATION CONTAINED IN THIS DRAWING IS THE SOLE PROPERTY OF RYADON INC. ANY REPRODUCTION IN PART OR AS A WHOLE WITHOUT THE WRITTEN PERMISSION OF RYADON INC. IS PROHIBITED.

TOLERANCES UNLESS OTHERWISE SPECIFIED:
 .X = ± .05
 .XX = ± .03
 .XXX = ± .015
 XIX = ± 1/32"
 ANGLE = ± 1°
 SURFACE = ± √

DESCRIPTION:
5632 SERIES
14" SLIDE
 MATERIAL:
STEEL
 FINISH:
ZINC PLATED

RYADON INC.

PART No. **I-DS-5632-14** REV **A**

SHEET 1 OF 1 | SCALE: NTS | SIZE A | DRAWN BY/DATE: KAS 4/6/16

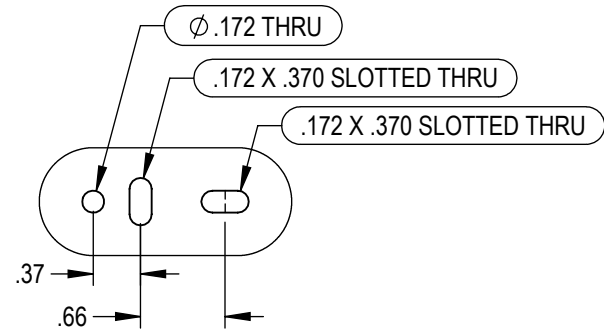
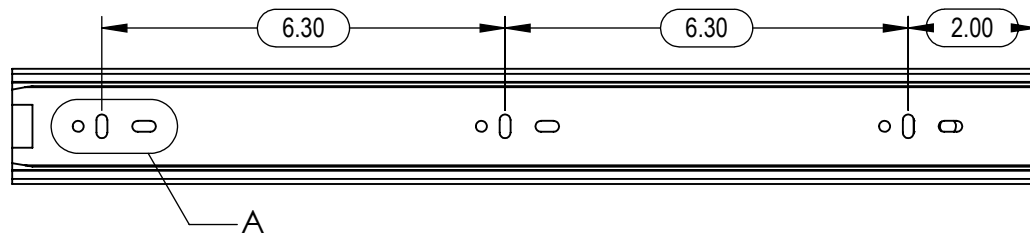

DETAIL A
SCALE 2 : 3

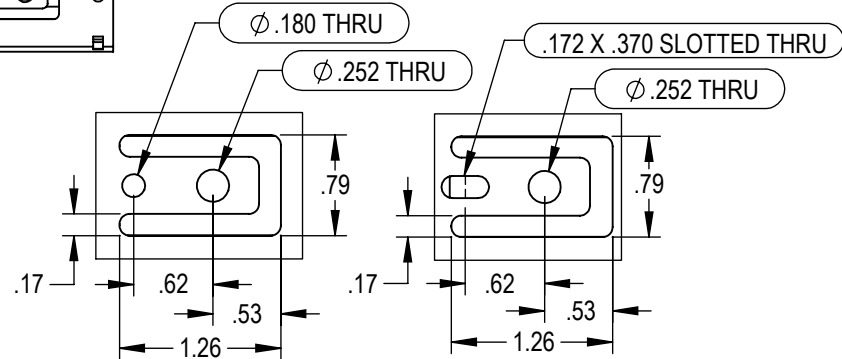
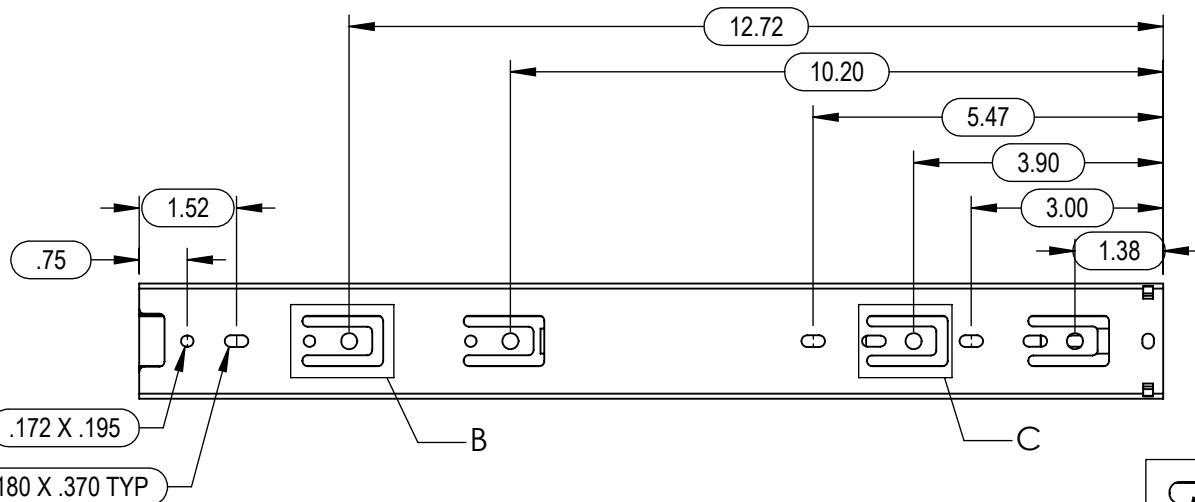

DETAIL B
SCALE 2 : 3

DETAIL C
SCALE 2 : 3

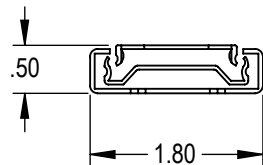
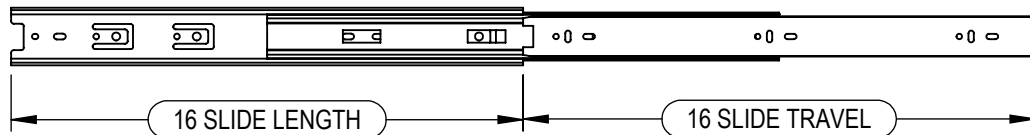

NOTES:

- 1) DO NOT SCALE DRAWING.
- 2) REMOVE ALL BURRS, NO SHARP EDGES.
- 3) MUST NOT HAVE SCRATCHES, DINGS, OR DENTS.
- 4) PART TO BE FREE FROM SURFACE IMPERFECTIONS OTHER THAN SURFACE FINISH REQUIREMENTS.
- 5) CRITICAL DIMENSIONS ARE INDICATED BY:
- 6) ALL ITEMS ARE TO BE INSPECTED TO 2.5 AQL SAMPLING PLAN UNLESS OTHERWISE STATED.
- 7) ENSURE PACKAGING WILL PROVIDE ADEQUATE PROTECTION DURING TRANSPORT.
- 8) GEOMETRIC FEATURES NOT DIMENSIONED ARE CONTROLLED BY 3D MODEL.

DEPT.	NAME	DATE
SALES		
ENG.		
Q.A.		

REVISIONS		
REV.	DESCRIPTION	DATE
A	INITIAL RELEASE	4/6/16

THE INFORMATION CONTAINED IN THIS DRAWING IS THE SOLE PROPERTY OF RYADON INC. ANY REPRODUCTION IN PART OR AS A WHOLE WITHOUT THE WRITTEN PERMISSION OF RYADON INC. IS PROHIBITED.

TOLERANCES UNLESS OTHERWISE SPECIFIED:
 .X = ± .05
 .XX = ± .03
 .XXX = ± .015
 XX = ± 1/32"
 ANGLE = ± 1°
 SURFACE = ±

DESCRIPTION:
5632 SERIES
16" SLIDE
 MATERIAL:
STEEL
 FINISH:
ZINC PLATED

RYADON INC.

PART No. **I-DS-5632-16** REV **A**

SHEET 1 OF 1 SCALE: NTS SIZE A DRAWN BY/DATE: KAS 4/6/16

6 5 4 3 2 1

D

D

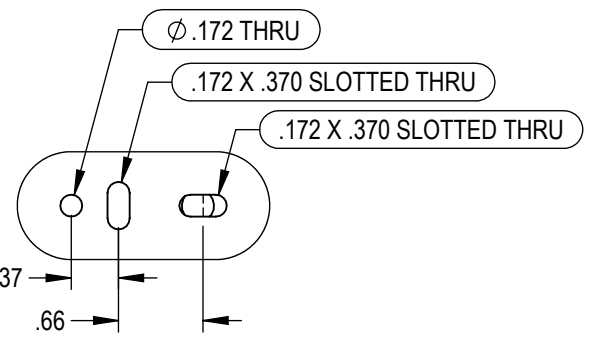
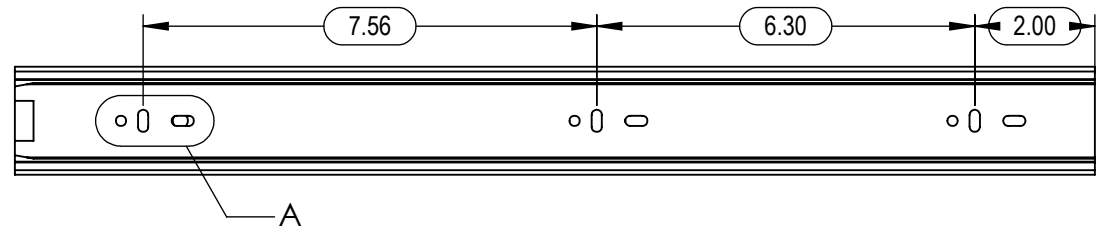

DETAIL A
SCALE 2 : 3

C

C

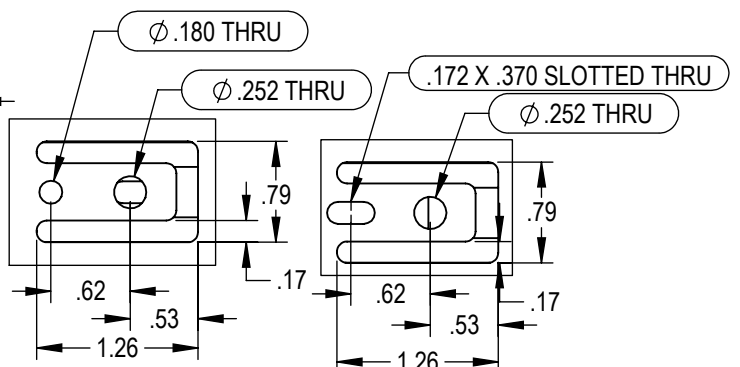
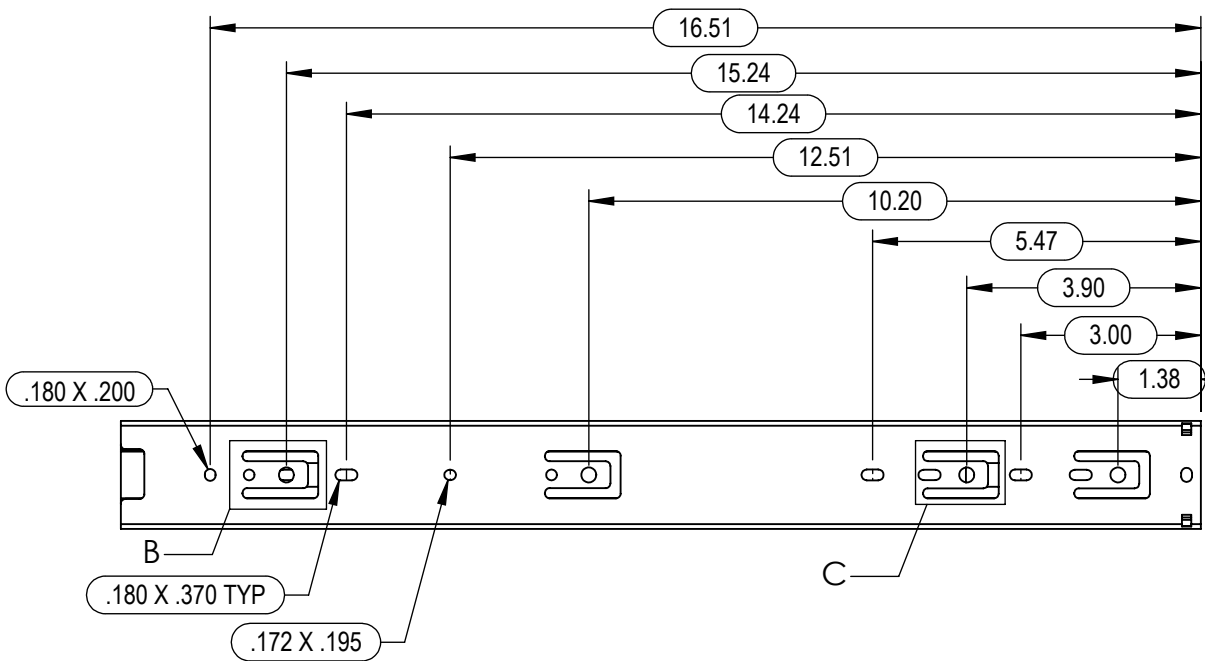

DETAIL B
SCALE 2 : 3

DETAIL C
SCALE 1 : 1.5

B

B

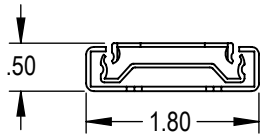
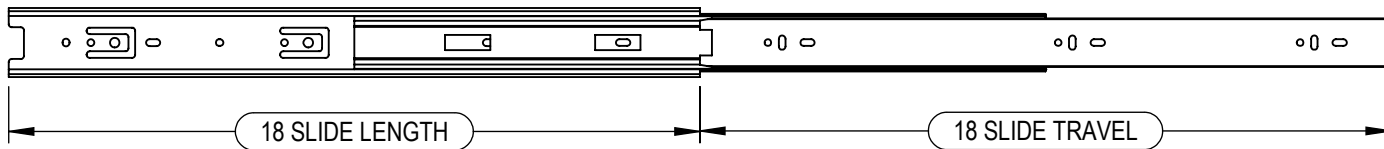

NOTES:

- 1) DO NOT SCALE DRAWING.
- 2) REMOVE ALL BURRS, NO SHARP EDGES.
- 3) MUST NOT HAVE SCRATCHES, DINGS, OR DENTS.
- 4) PART TO BE FREE FROM SURFACE IMPERFECTIONS OTHER THAN SURFACE FINISH REQUIREMENTS.
- 5) CRITICAL DIMENSIONS ARE INDICATED BY:
- 6) ALL ITEMS ARE TO BE INSPECTED TO 2.5 AQL SAMPLING PLAN UNLESS OTHERWISE STATED.
- 7) ENSURE PACKAGING WILL PROVIDE ADEQUATE PROTECTION DURING TRANSPORT.
- 8) GEOMETRIC FEATURES NOT DIMENSIONED ARE CONTROLLED BY 3D MODEL.

DEPT.	NAME	DATE
SALES		
ENG.		
Q.A.		

A

A

REV.	DESCRIPTION	DATE
A	INITIAL RELEASE	4/6/16

THE INFORMATION CONTAINED IN THIS DRAWING IS THE SOLE PROPERTY OF RYADON INC. ANY REPRODUCTION IN PART OR AS A WHOLE WITHOUT THE WRITTEN PERMISSION OF RYADON INC. IS PROHIBITED.

TOLERANCES UNLESS OTHERWISE SPECIFIED: .X = ± .05 .XX = ± .03 .XXX = ± .015 X/X = ± 1/32" ANGLE = ± 1° SURFACE = ± √	DESCRIPTION: 5632 SERIES 18" SLIDE MATERIAL: STEEL FINISH: ZINC PLATED
--	--

RYADON INC.

PART No. **I-DS-5632-18** REV **A**

SHEET 1 OF 1 SCALE: NTS SIZE A DRAWN BY/DATE: KAS 4/6/16

6 5 4 3 2 1

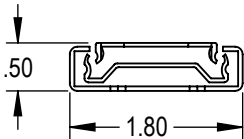
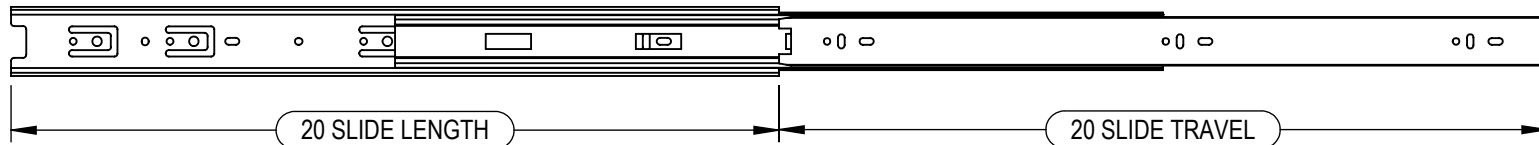
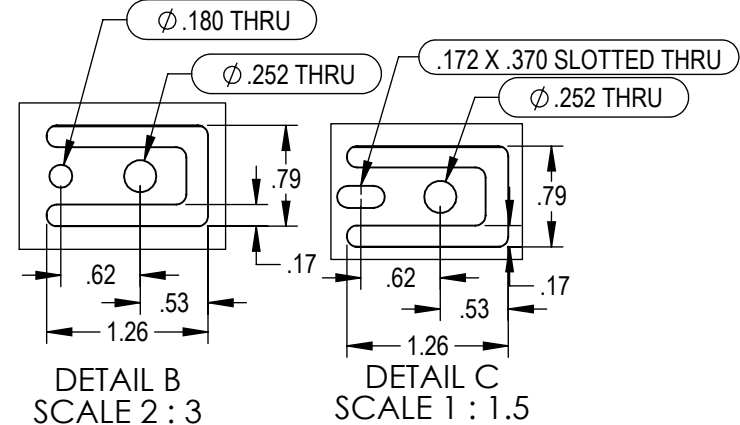
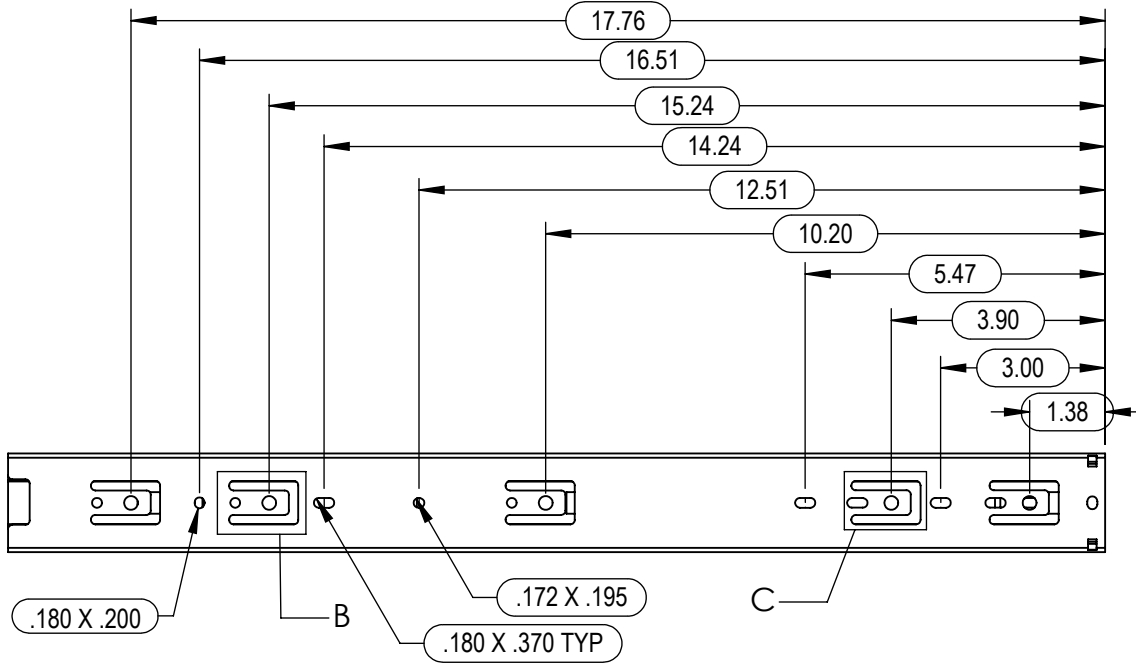
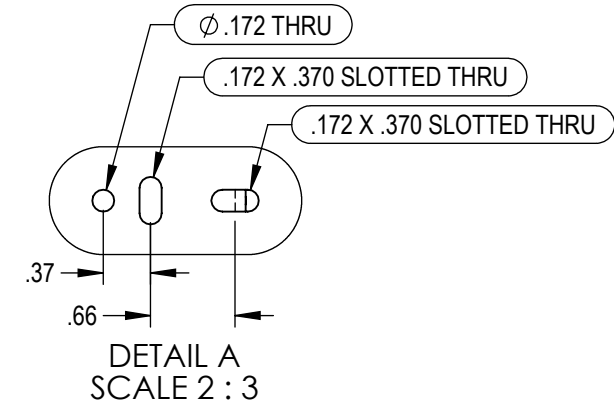
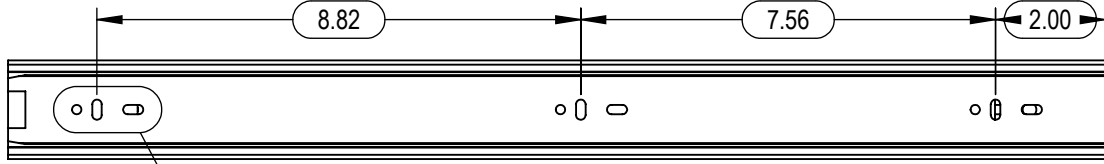

- NOTES:**
- DO NOT SCALE DRAWING.
 - REMOVE ALL BURRS, NO SHARP EDGES.
 - MUST NOT HAVE SCRATCHES, DINGS, OR DENTS.
 - PART TO BE FREE FROM SURFACE IMPERFECTIONS OTHER THAN SURFACE FINISH REQUIREMENTS.
 - CRITICAL DIMENSIONS ARE INDICATED BY
 - ALL ITEMS ARE TO BE INSPECTED TO 2.5 AQL SAMPLING PLAN UNLESS OTHERWISE STATED.
 - ENSURE PACKAGING WILL PROVIDE ADEQUATE PROTECTION DURING TRANSPORT.
 - GEOMETRIC FEATURES NOT DIMENSIONED ARE CONTROLLED BY 3D MODEL.

DEPT.	NAME	DATE
SALES		
ENG.		
Q.A.		

REVISIONS		
REV.	DESCRIPTION	DATE
A	INITIAL RELEASE	4/6/16

THE INFORMATION CONTAINED IN THIS DRAWING IS THE SOLE PROPERTY OF RYADON INC. ANY REPRODUCTION IN PART OR AS A WHOLE WITHOUT THE WRITTEN PERMISSION OF RYADON INC. IS PROHIBITED.

TOLERANCES UNLESS OTHERWISE SPECIFIED: .X = ± .05 .XX = ± .03 .XXX = ± .015 X/X = ± 1/32" ANGLE = ± 1° SURFACE = ± √	DESCRIPTION: 5632 SERIES 20" SLIDE MATERIAL: STEEL FINISH: ZINC PLATED
--	--

RYADON INC.

PART No. **I-DS-5632-20** REV **A**

SHEET 1 OF 1 SCALE: NTS SIZE A DRAWN BY/DATE: KAS 4/6/16

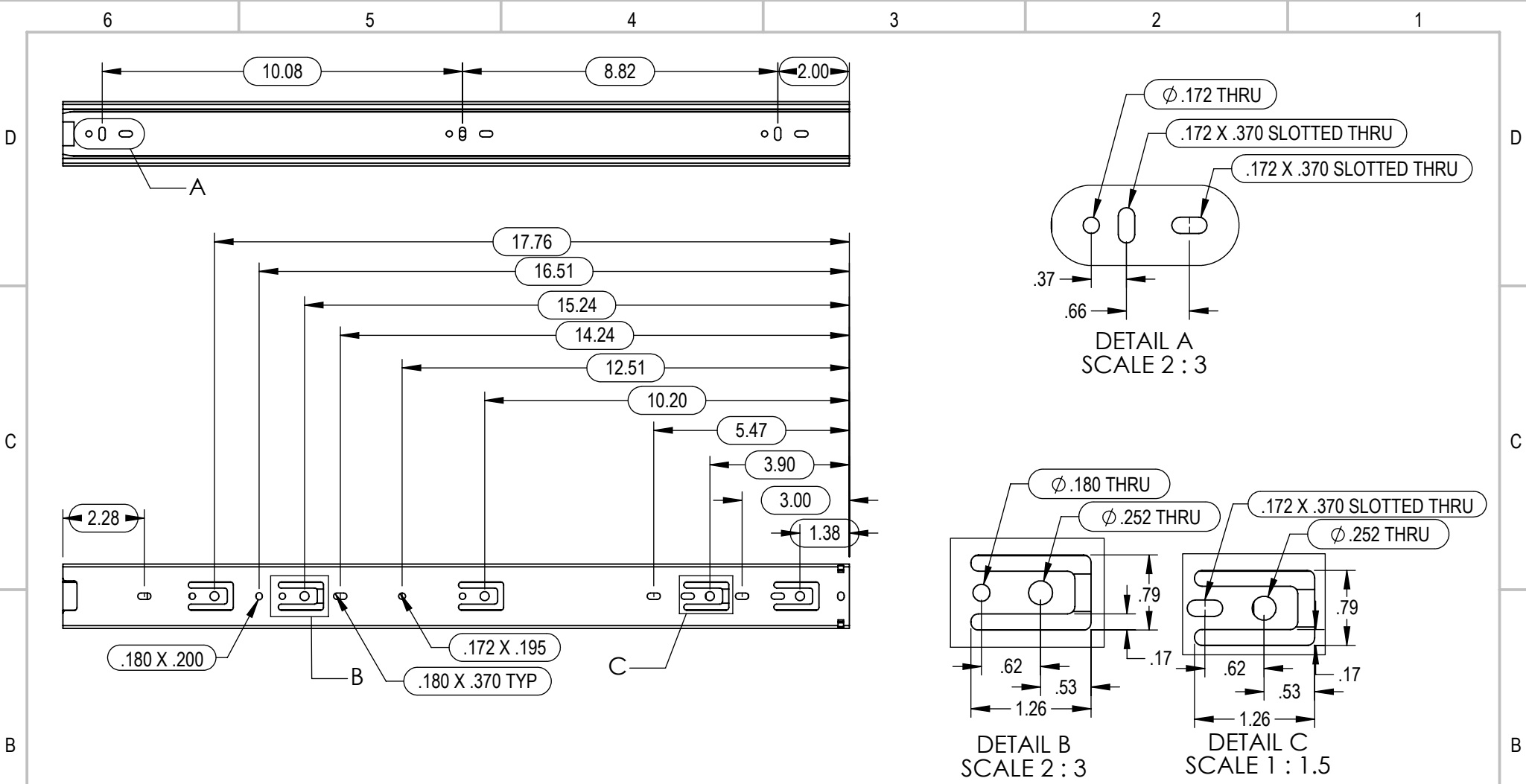

- NOTES:**
- 1) DO NOT SCALE DRAWING.
 - 2) REMOVE ALL BURRS, NO SHARP EDGES.
 - 3) MUST NOT HAVE SCRATCHES, DINGS, OR DENTS.
 - 4) PART TO BE FREE FROM SURFACE IMPERFECTIONS OTHER THAN SURFACE FINISH REQUIREMENTS.
 - 5) CRITICAL DIMENSIONS ARE INDICATED BY:
 - 6) ALL ITEMS ARE TO BE INSPECTED TO 2.5 AQL SAMPLING PLAN UNLESS OTHERWISE STATED.
 - 7) ENSURE PACKAGING WILL PROVIDE ADEQUATE PROTECTION DURING TRANSPORT.
 - 8) GEOMETRIC FEATURES NOT DIMENSIONED ARE CONTROLLED BY 3D MODEL.

DEPT.	NAME	DATE
SALES		
ENG.		
Q.A.		

REVISIONS		
REV.	DESCRIPTION	DATE
A	INITIAL RELEASE	4/6/16

TOLERANCES UNLESS OTHERWISE SPECIFIED: .X = ± .05 .XX = ± .03 .XXX = ± .015 X/X = ± 1/32" ANGLE = ± 1° SURFACE = ± √	DESCRIPTION: 5632 SERIES 22" SLIDE MATERIAL: STEEL FINISH: ZINC PLATED
--	--

RYADON INC.

PART No. **I-DS-5632-22** REV **A**

SHEET 1 OF 1 SCALE: NTS SIZE A DRAWN BY/DATE: KAS 4/6/16

D

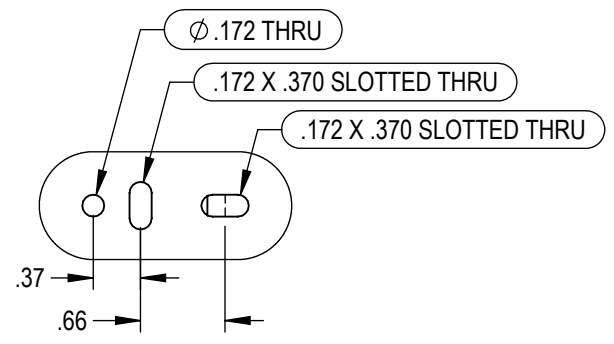
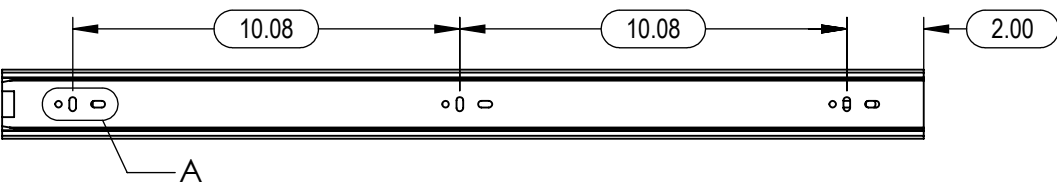

DETAIL A
SCALE 2 : 3

C

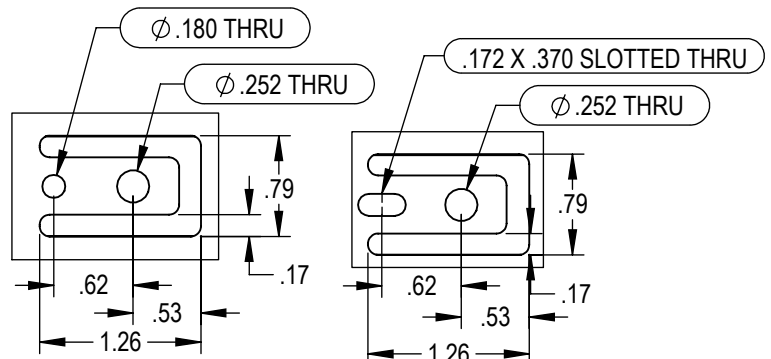
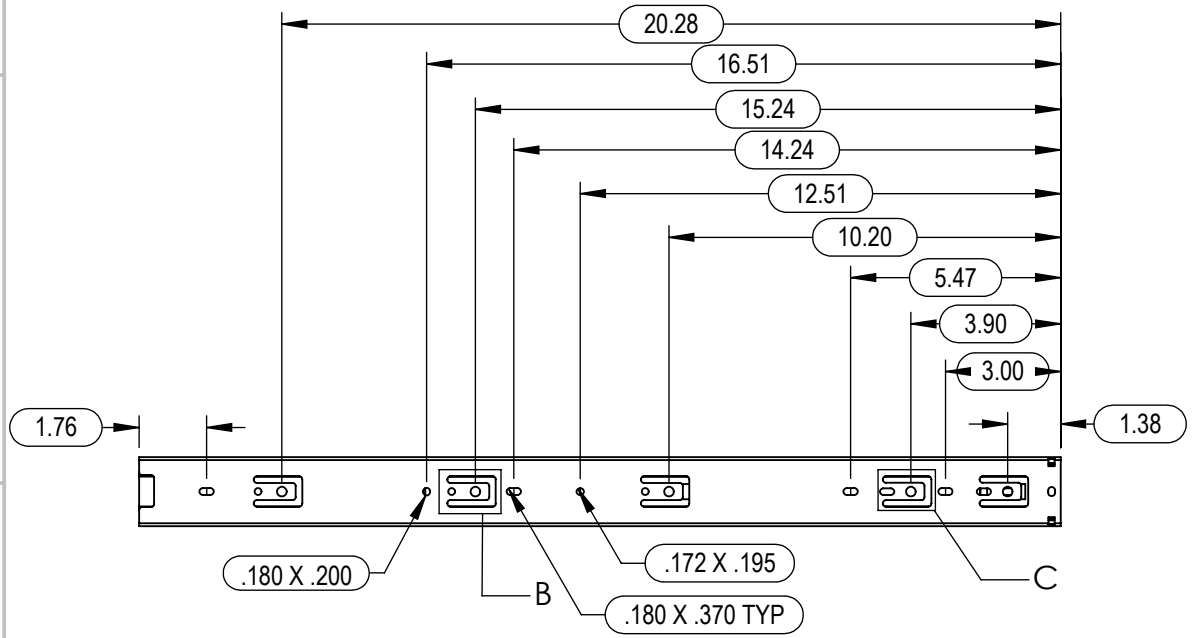

DETAIL B
SCALE 2 : 3

DETAIL C
SCALE 1 : 1.5

B

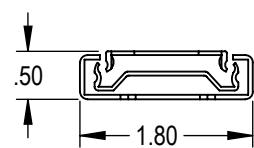
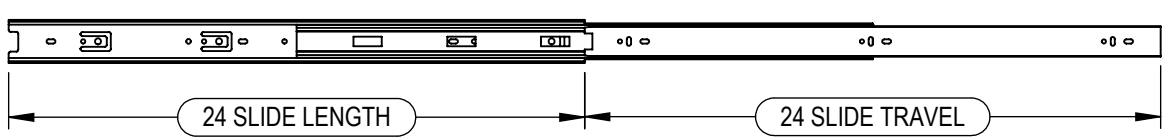

NOTES:

- 1) DO NOT SCALE DRAWING.
- 2) REMOVE ALL BURRS, NO SHARP EDGES.
- 3) MUST NOT HAVE SCRATCHES, DINGS, OR DENTS.
- 4) PART TO BE FREE FROM SURFACE IMPERFECTIONS OTHER THAN SURFACE FINISH REQUIREMENTS.
- 5) CRITICAL DIMENSIONS ARE INDICATED BY
- 6) ALL ITEMS ARE TO BE INSPECTED TO 2.5 AQL SAMPLING PLAN UNLESS OTHERWISE STATED.
- 7) ENSURE PACKAGING WILL PROVIDE ADEQUATE PROTECTION DURING TRANSPORT.
- 8) GEOMETRIC FEATURES NOT DIMENSIONED ARE CONTROLLED BY 3D MODEL.

DEPT.	NAME	DATE
SALES		
ENG.		
Q.A.		

A

REVISIONS		
REV.	DESCRIPTION	DATE
A	INITIAL RELEASE	4/6/16

TOLERANCES UNLESS OTHERWISE SPECIFIED:
.X = ± .05
.XX = ± .03
.XXX = ± .015
XX = ± 1/32"
ANGLE = ± 1°
SURFACE = ±

DESCRIPTION:	5632 SERIES
	24" SLIDE
MATERIAL:	STEEL
FINISH:	ZINC PLATED

RYADON INC.

PART No. I-DS-5632-24

SHEET 1 OF 1 | SCALE: NTS | SIZE A | DRAWN BY/DATE: KAS 4/6/16

THE INFORMATION CONTAINED IN THIS DRAWING IS THE SOLE PROPERTY OF RYADON INC. ANY REPRODUCTION IN PART OR AS A WHOLE WITHOUT THE WRITTEN PERMISSION OF RYADON INC. IS PROHIBITED.

D

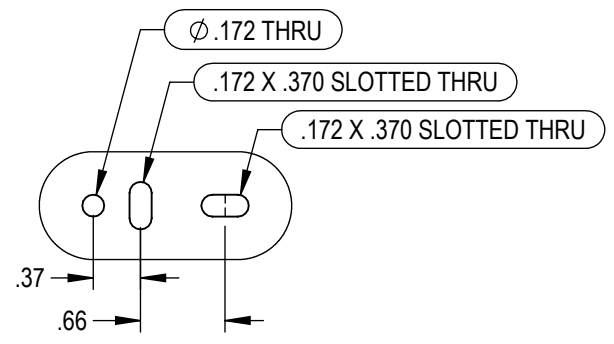
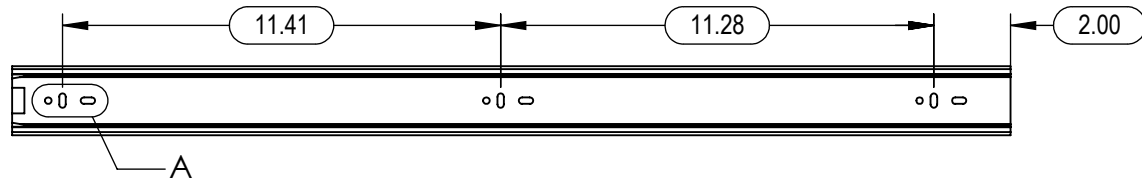

DETAIL A
SCALE 2 : 3

C

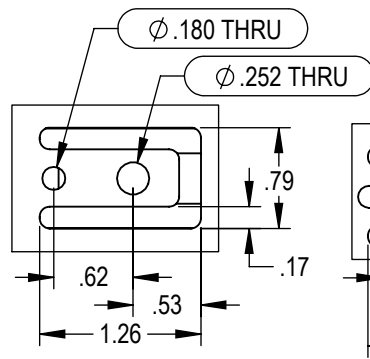
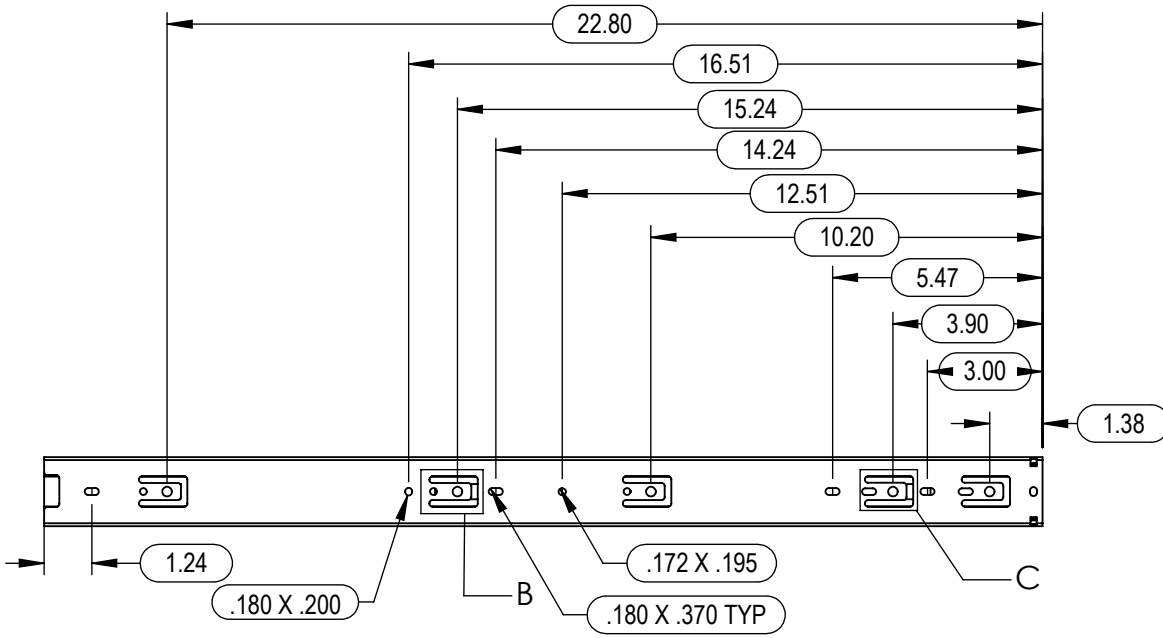

DETAIL B
SCALE 2 : 3

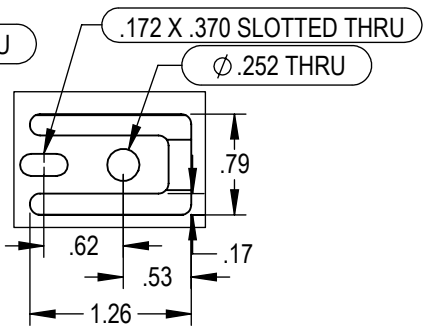

DETAIL C
SCALE 1 : 1.5

B

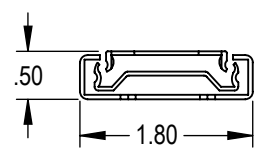
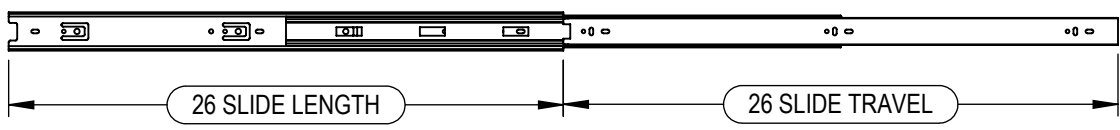

NOTES:

- 1) DO NOT SCALE DRAWING.
- 2) REMOVE ALL BURRS, NO SHARP EDGES.
- 3) MUST NOT HAVE SCRATCHES, DINGS, OR DENTS.
- 4) PART TO BE FREE FROM SURFACE IMPERFECTIONS OTHER THAN SURFACE FINISH REQUIREMENTS.
- 5) CRITICAL DIMENSIONS ARE INDICATED BY
- 6) ALL ITEMS ARE TO BE INSPECTED TO 2.5 AQL SAMPLING PLAN UNLESS OTHERWISE STATED.
- 7) ENSURE PACKAGING WILL PROVIDE ADEQUATE PROTECTION DURING TRANSPORT.
- 8) GEOMETRIC FEATURES NOT DIMENSIONED ARE CONTROLLED BY 3D MODEL.

DEPT.	NAME	DATE
SALES		
ENG.		
Q.A.		

A

REVISIONS		
REV.	DESCRIPTION	DATE
A	INITIAL RELEASE	4/6/16

THE INFORMATION CONTAINED IN THIS DRAWING IS THE SOLE PROPERTY OF RYADON INC. ANY REPRODUCTION IN PART OR AS A WHOLE WITHOUT THE WRITTEN PERMISSION OF RYADON INC. IS PROHIBITED.

TOLERANCES UNLESS OTHERWISE SPECIFIED: .X = ± .05 .XX = ± .03 .XXX = ± .015 X/X = ± 1/32" ANGLE = ± 1° SURFACE = ± √
--

DESCRIPTION: 5632 SERIES 26" SLIDE
MATERIAL: STEEL
FINISH: ZINC PLATED

RYADON INC.

PART No. I-DS-5632-26

SHEET 1 OF 1 | SCALE: NTS | SIZE A | DRAWN BY/DATE: KAS 4/6/16

D

C

B

A

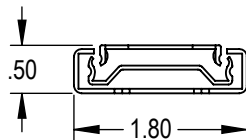
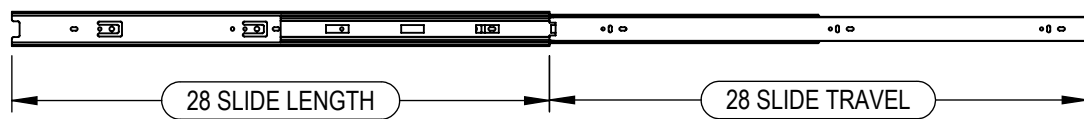
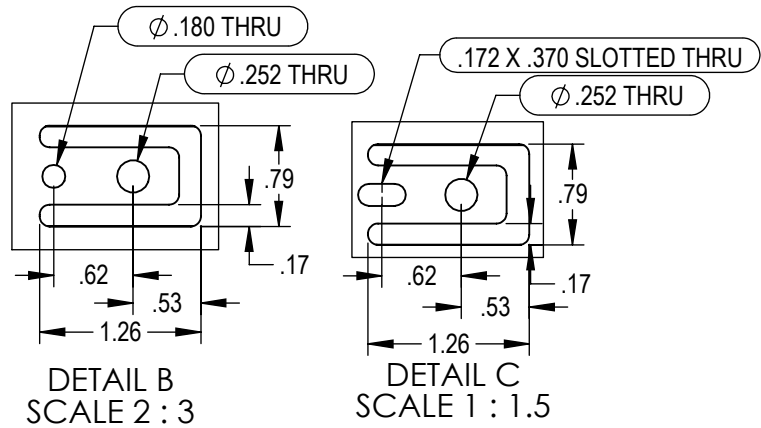
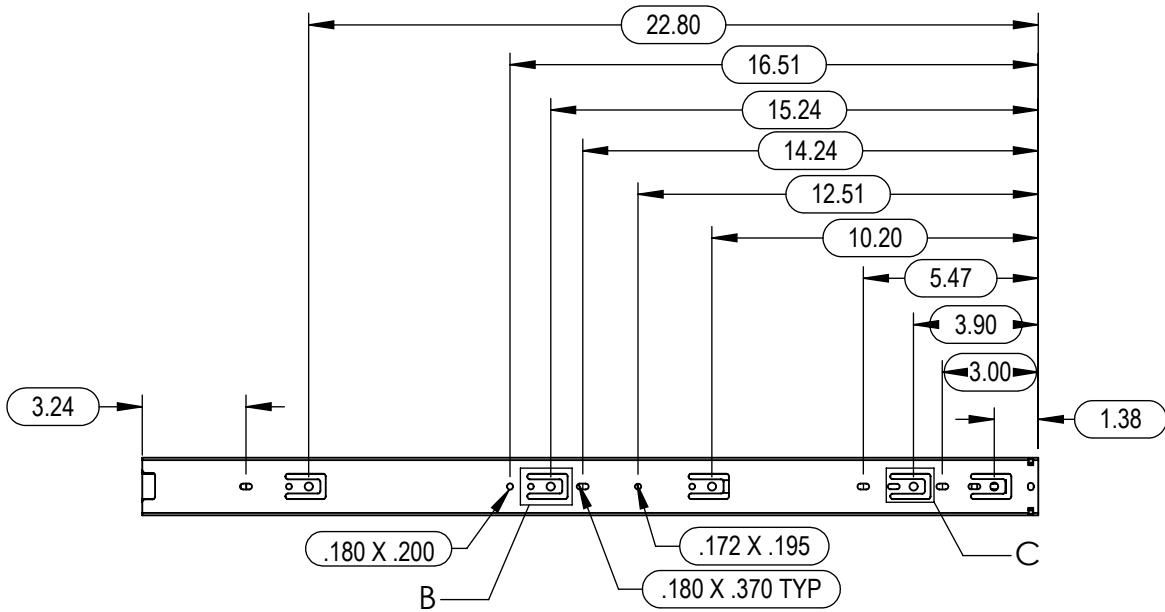
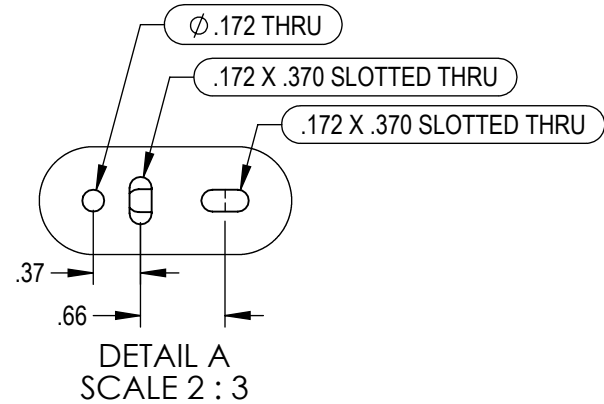
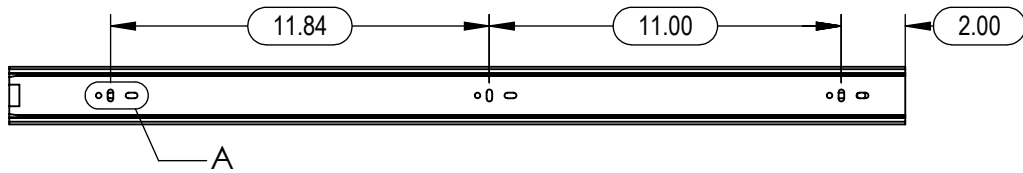

NOTES:

- 1) DO NOT SCALE DRAWING.
- 2) REMOVE ALL BURRS, NO SHARP EDGES.
- 3) MUST NOT HAVE SCRATCHES, DINGS, OR DENTS.
- 4) PART TO BE FREE FROM SURFACE IMPERFECTIONS OTHER THAN SURFACE FINISH REQUIREMENTS.
- 5) CRITICAL DIMENSIONS ARE INDICATED BY .
- 6) ALL ITEMS ARE TO BE INSPECTED TO 2.5 AQL SAMPLING PLAN UNLESS OTHERWISE STATED.
- 7) ENSURE PACKAGING WILL PROVIDE ADEQUATE PROTECTION DURING TRANSPORT.
- 8) GEOMETRIC FEATURES NOT DIMENSIONED ARE CONTROLLED BY 3D MODEL.

DEPT.	NAME	DATE
SALES		
ENG.		
Q.A.		

REVISIONS		
REV.	DESCRIPTION	DATE
A	INITIAL RELEASE	4/6/16

THE INFORMATION CONTAINED IN THIS DRAWING IS THE SOLE PROPERTY OF RYADON INC. ANY REPRODUCTION IN PART OR AS A WHOLE WITHOUT THE WRITTEN PERMISSION OF RYADON INC. IS PROHIBITED.

TOLERANCES UNLESS OTHERWISE SPECIFIED:
 .X = ± .05
 .XX = ± .03
 .XXX = ± .015
 XIX = ± 1/32"
 ANGLE = ± 1°
 SURFACE = ±

DESCRIPTION:
5632 SERIES
28" SLIDE
 MATERIAL:
STEEL
 FINISH:
ZINC PLATED

RYADON INC.

PART No. **I-DS-5632-28** REV **A**

SHEET 1 OF 1 SCALE: NTS SIZE A DRAWN BY/DATE: KAS 4/6/16

D

D

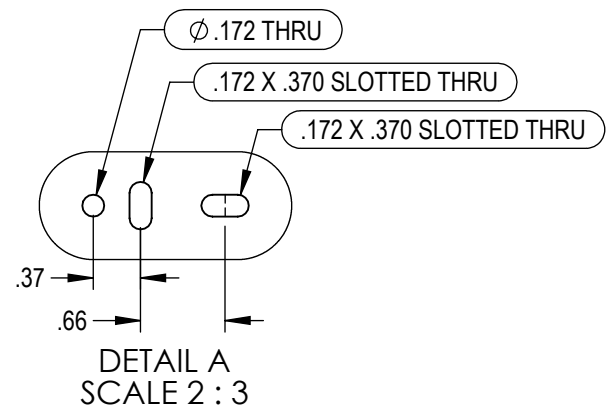
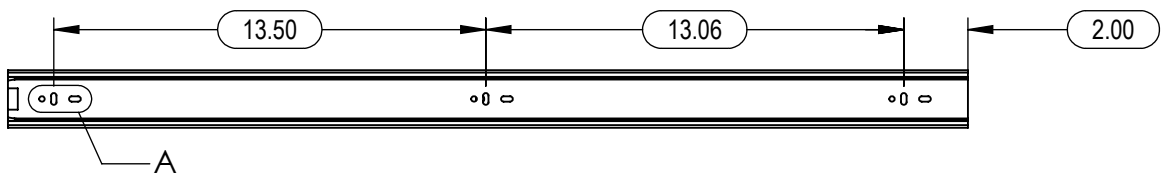

C

C

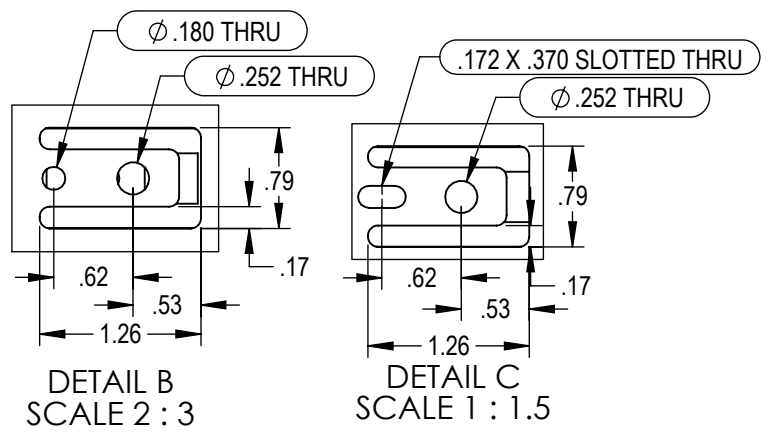
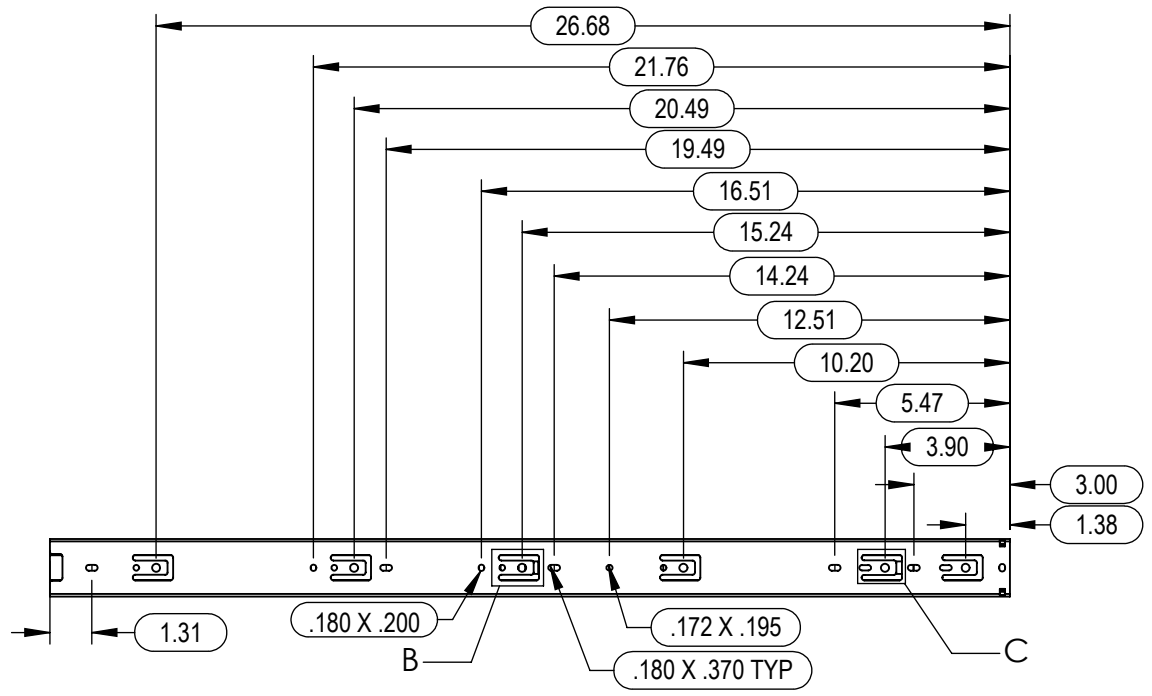

B

B

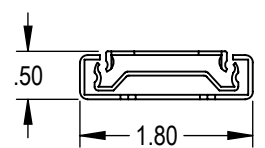
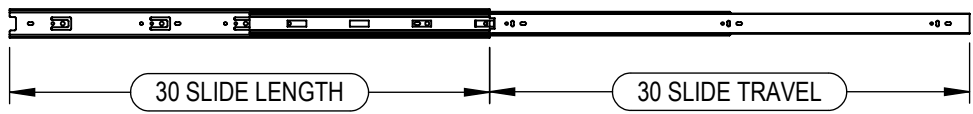

- NOTES:**
- DO NOT SCALE DRAWING.
 - REMOVE ALL BURRS, NO SHARP EDGES.
 - MUST NOT HAVE SCRATCHES, DINGS, OR DENTS.
 - PART TO BE FREE FROM SURFACE IMPERFECTIONS OTHER THAN SURFACE FINISH REQUIREMENTS.
 - CRITICAL DIMENSIONS ARE INDICATED BY:
 - ALL ITEMS ARE TO BE INSPECTED TO 2.5 AQL SAMPLING PLAN UNLESS OTHERWISE STATED.
 - ENSURE PACKAGING WILL PROVIDE ADEQUATE PROTECTION DURING TRANSPORT.
 - GEOMETRIC FEATURES NOT DIMENSIONED ARE CONTROLLED BY 3D MODEL.

DEPT.	NAME	DATE
SALES		
ENG.		
Q.A.		

A

A

REVISIONS		
REV.	DESCRIPTION	DATE
A	INITIAL RELEASE	4/6/16

THE INFORMATION CONTAINED IN THIS DRAWING IS THE SOLE PROPERTY OF RYADON INC. ANY REPRODUCTION IN PART OR AS A WHOLE WITHOUT THE WRITTEN PERMISSION OF RYADON INC. IS PROHIBITED.

TOLERANCES UNLESS OTHERWISE SPECIFIED: .X = ± .05 .XX = ± .03 .XXX = ± .015 X/X = ± 1/32" ANGLE = ± 1° SURFACE = ± √	DESCRIPTION: 5632 SERIES 30" SLIDE MATERIAL: STEEL FINISH: ZINC PLATED
--	--

RYADON INC.

PART No. **I-DS-5632-30** REV **A**

SHEET 1 OF 1 SCALE: NTS SIZE A DRAWN BY/DATE: KAS 4/6/16

D

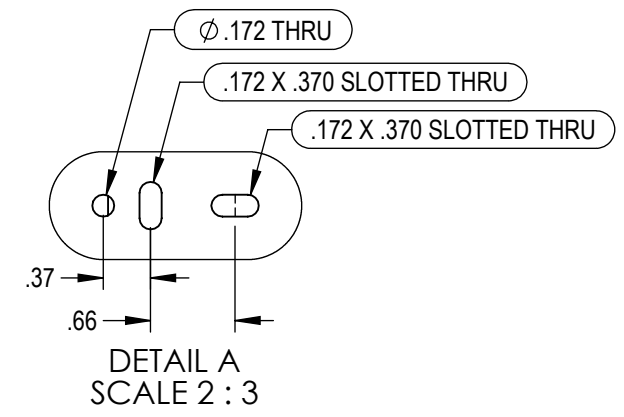
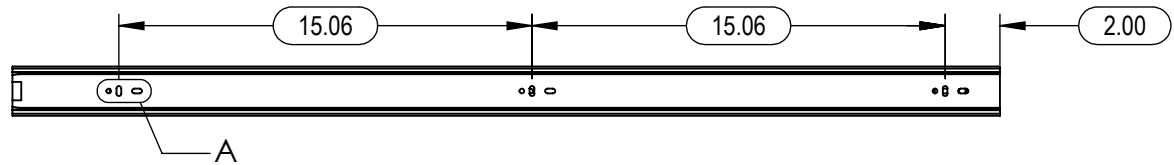

C

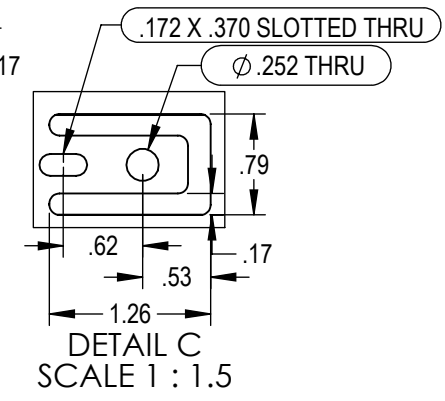
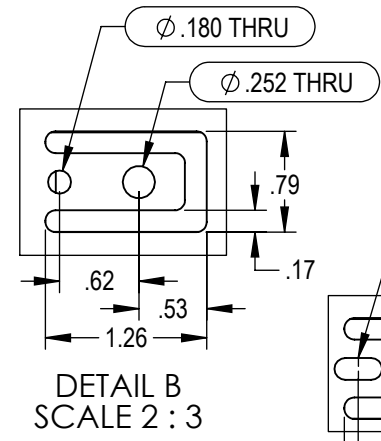
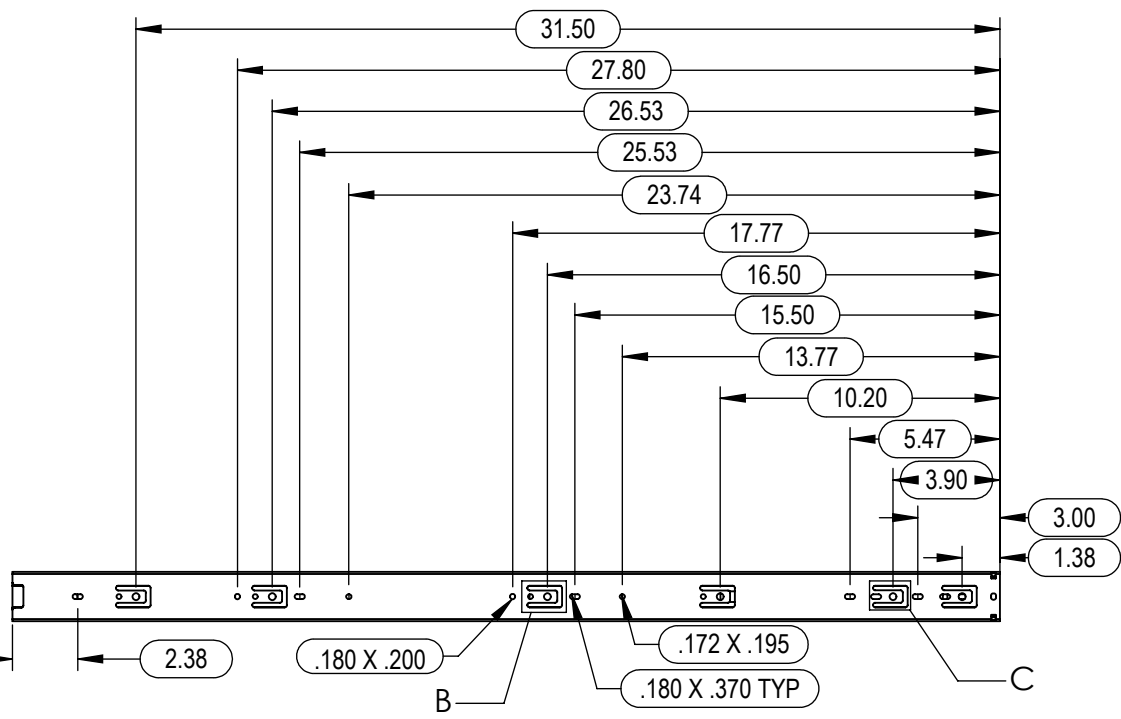

B

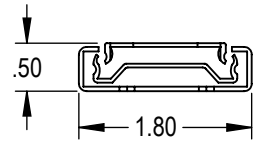
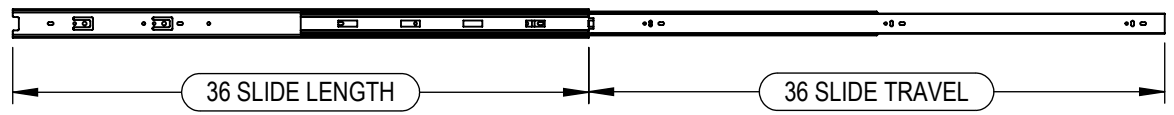

NOTES:

- 1) DO NOT SCALE DRAWING.
- 2) REMOVE ALL BURRS, NO SHARP EDGES.
- 3) MUST NOT HAVE SCRATCHES, DINGS, OR DENTS.
- 4) PART TO BE FREE FROM SURFACE IMPERFECTIONS OTHER THAN SURFACE FINISH REQUIREMENTS.
- 5) CRITICAL DIMENSIONS ARE INDICATED BY .
- 6) ALL ITEMS ARE TO BE INSPECTED TO 2.5 AQL SAMPLING PLAN UNLESS OTHERWISE STATED.
- 7) ENSURE PACKAGING WILL PROVIDE ADEQUATE PROTECTION DURING TRANSPORT.
- 8) GEOMETRIC FEATURES NOT DIMENSIONED ARE CONTROLLED BY 3D MODEL.

DEPT.	NAME	DATE
SALES		
ENG.		
Q.A.		

A

REVISIONS		
REV.	DESCRIPTION	DATE
A	INITIAL RELEASE	4/6/16

THE INFORMATION CONTAINED IN THIS DRAWING IS THE SOLE PROPERTY OF RYADON INC. ANY REPRODUCTION IN PART OR AS A WHOLE WITHOUT THE WRITTEN PERMISSION OF RYADON INC. IS PROHIBITED.

TOLERANCES UNLESS OTHERWISE SPECIFIED:
 .X = ± .05
 .XX = ± .03
 .XXX = ± .015
 X/X = ± 1/32"
 ANGLE = ± 1°
 SURFACE = ± √

DESCRIPTION:
5632 SERIES
36" SLIDE
 MATERIAL:
STEEL
 FINISH:
ZINC PLATED

RYADON INC.

PART No. **I-DS-5632-36** REV **A**

SHEET 1 OF 1 SCALE: NTS SIZE A DRAWN BY/DATE: KAS 4/6/16